

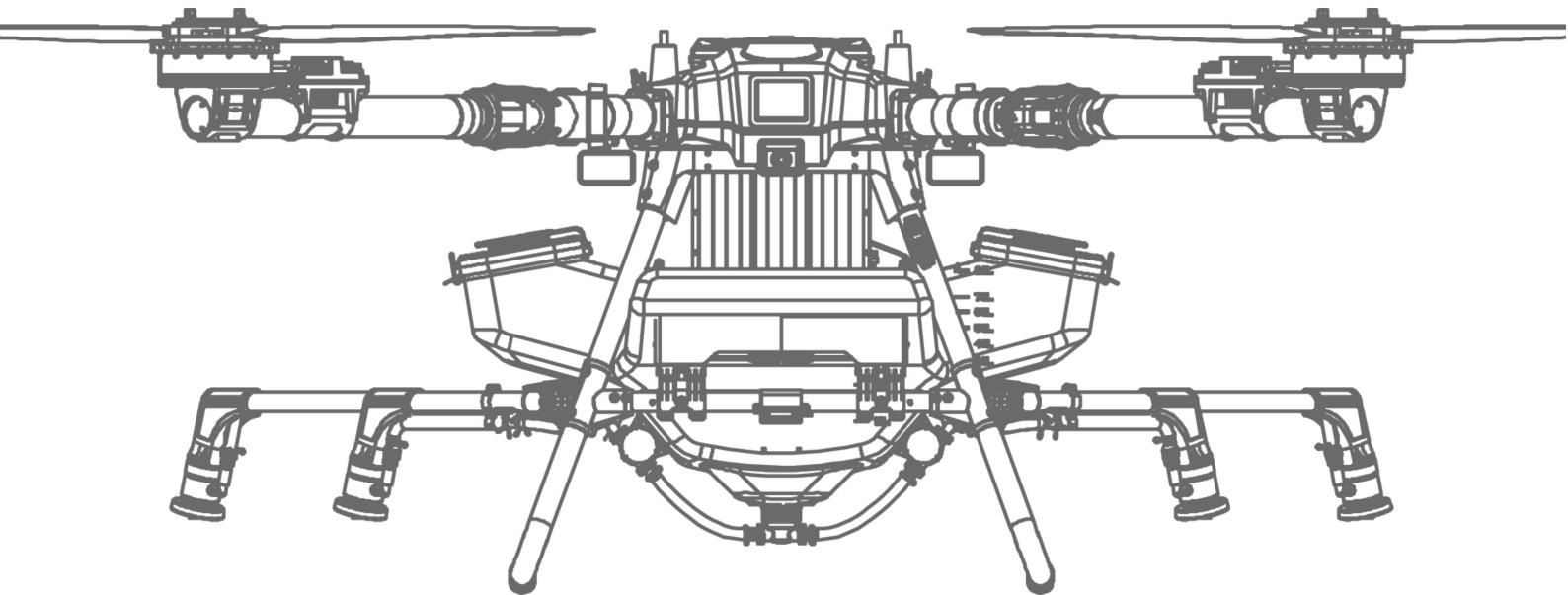

Z80 Agricultural Drone

User Manual

Version 1.0 EN



Contents

1	Safety Information and Precautions	1
1.1	Safety Instructions	1
1.2	Hazard Response Measures	2
2	Product Overview	4
2.1	Product Introduction	4
2.2	Drone Parts	4
2.3	Remote Control	5
2.4	Battery	7
2.5	Charger	7
3	Flight Preparation	9
3.1	Device Activation	9
3.1.1	Account Registration	9
3.1.2	G20 Binding	9
3.2	Operating Environment	10
3.3	Pre-flight Inspection	11
3.4	Calibration	11
3.4.1	Controller Calibration	12
3.4.2	Magnetic calibration	12
3.4.3	Horizontal Calibration	12
3.4.4	Weight Calibration	12
3.4.5	Pump Calibration	13
3.4.6	Spreader Calibration	14
3.4.7	Voltage Calibration	15
3.5	Flight	16
4	Drone Operation	18
4.1	Remote Control	18
4.1.1	Remote Control Gear	18
4.1.2	Rocker Mode	18
4.1.3	Homepage	20
4.1.4	G20 Device Tool APP	20
4.2	APP Overview	21
4.2.1	Homepage	21
4.2.2	Start the operation	22
4.2.3	APP Settings	24
4.3	Operation Mode	24
4.3.1	Add Block	24
4.3.2	AB Mode	27
4.3.3	Manual Mode	28
4.3.4	Breakpoint Resume	29
4.3.5	Manual obstacle avoidance	30
4.4	Spray/Spread Mode	31
4.5	Indicator Light Instruction	31

4.5.1 Motor Indicator Light	31
4.5.2 Motor indicator light Signals	32
4.5.3 Battery indicator light	33
4.6 Headlight Instruction	33
4.7 Battery Instructions	34
4.8 Charger Instructions	34
4.8.1 Charger Interface	34
4.8.2 Charger Usage	35
5 Maintenance	36
5.1 Drone Maintenance	36
5.2 Battery Maintenance	36
5.3 Updates	36
6 Specifications and Appendix	38
6.1 Specifications	38
6.2 Disclaimer	39

1 Safety Information and Precautions

1.1 Safety Instructions

User requirements

Agricultural drones should be operated by professional who are at least 18 years old. Operators must be familiar with the performance, operation and regulations of drones. Operations without training are forbidden.

Environment Safety

Weather Conditions: Avoid operation in adverse weather, such as strong winds (wind speed exceeding the 6m/s), heavy rain, lightning, heavy fog, etc. which may cause control loss, damage, or affect operation effect.

Geographical environment: Flying in an open, flat, unobstructed area and away from crowds, buildings, high-voltage wires, airports and other no-fly zones and sensitive areas. If flying in hilly areas or complex terrain, pay attention to undulations and barriers to prevent collision.

Air traffic control: Comply with local laws and regulations, fly within permitted airspace, avoid entering restricted airspace or interfering with the normal flights.

Equipment inspection

Before each flight, Check each part of the drone, including frame structure,propellers condition ,motors running,battery power and cables connection,etc. Make sure the drone is ready to take a flight.

Check the spray system and make sure nozzles unobstructed, no leakage, and the flow meters and sensors are working properly ,ensuring uniformity and accuracy.

Pesticide safety

When mixing and adding pesticides, operators should wear protective clothing, gloves, masks and other protective equipment to avoid contact between pesticides and the skin and respiratory tract. Mix pesticides strictly according to the instructions for use to prevent excessive or low concentrations of pesticides from affecting the control effect.

During the operation, pay attention to wind direction and speed to prevent pesticides from drifting to non-operation areas, causing environmental pollution and harm to people, animals and plants. After the operation, clean the drone and related equipment in time and properly dispose of remaining pesticides and waste.

Flight Safety

Keep a safe distance from people and objects when taking-off and landing. During the flight, pay attention to the flight status and parameters, such as altitude, speed, battery power, signal strength, etc. If any abnormality, take emergency landing or homing in time.

Don't interfere the drone and keep effectively control during the flight. If signal loss or losing control, do not panic, and operate according to the pre-set protection procedures such as home or hover.

Battery Safety

Use official batteries, don't use inferior or mismatched batteries to avoid accidents such as fire and explosion.

Use the matching charger and charging in correct method and requirements, avoid charging in high temperature, humid or flammable environments.

Store batteries in proper place and avoid overcharging, over-discharging or overheat. Check and maintain the batteries regularly, if battery bulging or leakage or other abnormality, stop using immediately and dispose of it properly.

1.2 Hazard Response Measures

Operators should strictly follow safety regulations, regularly maintain the drones, remain calm when hazards occur, and effectively response to ensure safety of operation, persons and environment.

Agricultural drone hazards and countermeasures are as follows:

Hazard Type	Description	Countermeasures
Mechanical Failure	Propeller damage cause drone imbalance and crash, potentially harming persons and damaging crops or facilities.	Before flying, check propellers for cracks or wear and replace if any. Regularly check screw tightness.
	Motor failure causes the drone to lack power, unable to fly and may fall.	Maintain the motor regularly, clean the dust and debris, check its cable connection, and if any abnormal heat or noisy, send to repair or replace it in time.
	The drone structure damage affects flight stability and safety.	Check the frame before and after each flight. If any cracks, deformation or others, stop using and repair it or contact local agent for after-sales
Electrical Failure	Battery overheat, fire or explosion harms surroundings and causes drone crash.	Using official batteries, avoid over charging and over-discharging, charge in well-ventilated place and away from flammable. Equipped with battery explosion-proof box, monitor battery temp during flight, if any abnormality, land the drone immediately and stay away.
	Circuit short causes losing control or system failure.	Regularly check the drone's internal circuits to see if cables damaged, aged, or have short circuit. If any problem, repair or replace it in time.
Loss of control	Signal interference causes losing control, may cause drone flying around and colliding.	Try to fly in an area away from strong signal sources (such as large base stations, high-voltage lines, etc.). Check the signal strength of the remote control and the drone before flying. If the signal weakens, adjust the flight position or altitude in time. If necessary, set the out-of-control automatic return and ensure the safety of the return path.
	Abnormal GNSS positioning cause the drone to deviate from the preset route and may fly into a no-fly zone or dangerous area.	Make sure the GNSS signal is good and positioning accurate before flight. If there is a positioning drift, calibrate the GPS or change the flight site, and set up an electronic fence to prevent accidentally entering the danger zone.
Pesticide	Pesticide leakage pollutes the soil, water and crops, damaging Eco-environment.	Before flight, check the sealing of tank and spray system and if any pipes damage. After operation, clean spray system in time to avoid pesticide leakage or residue.

	Pesticide drift harms animals, plants and people in non-operation areas.	Reasonably set the flight route and height according to weather conditions (especially wind direction and speed), adjust the nozzle angle and spray pressure to reduce drift, and set up a buffer zone if necessary.
Collision	Collisions on obstacles such as buildings, trees, and poles damage the drone and even cause secondary accidents.	Check the site before flight, mark and avoid the barriers when setting route. During flight, enable obstacle avoidance (if available) and be alert for manual intervention.
	Collision with flying objects such as birds affects flight stability.	Try to avoid flying near bird migration routes or habitats. Use devices or make noise to drive birds. If collision, check the damage and evaluate whether to operate or not.

2 Product Overview

2.1 Product Introduction

Z80 is an 80 kg agricultural drone in the Z-Series, designed for heavy-duty farming operations. It combines spraying, spreading, and lifting in a single, versatile platform. Dual flexible impeller pumps paired with four centrifugal nozzles deliver efficient and thorough spraying, while the auger spreader ensures smooth, high-flow spreading. The 7-inch large-screen remote and the upgraded Flight Assistant app provide a seamless and effortless control experience.

Featuring a new modular metal frame and the EFT 4.0 control system, every flight is stable and efficient. Building on the Z Series' waterproof and intelligent control design, the Z80 introduces modular flight control, new centrifugal nozzles, a 36 L/min impeller pump, 13.8 m/s high-speed spreading, and high-precision radar, making farming operations easier and more reliable.

2.2 Drone Parts

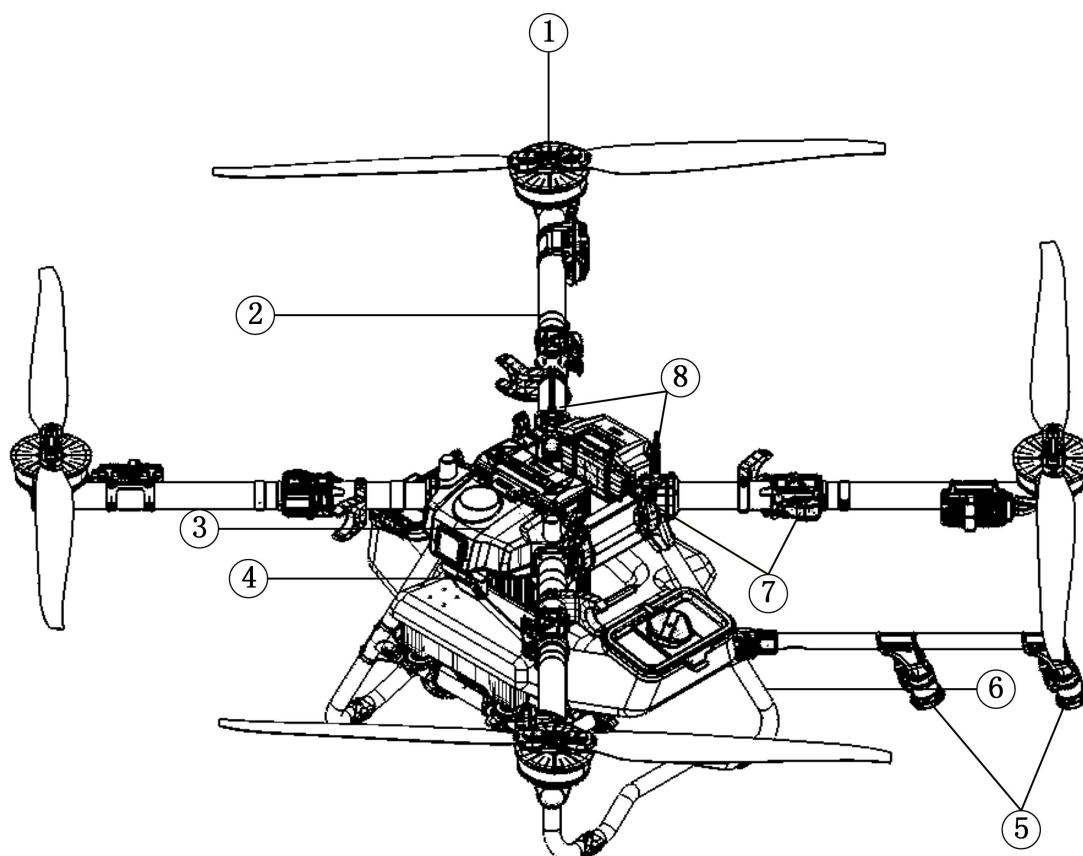

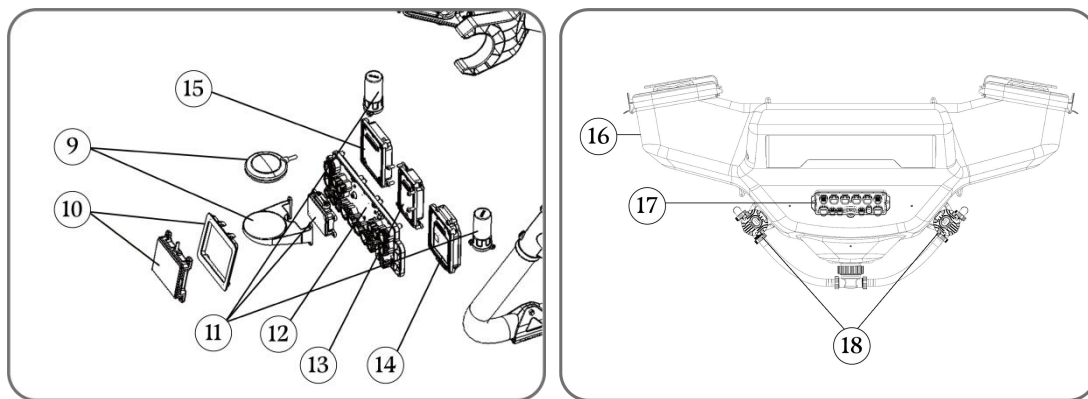

- | | |
|-----------------------|----------------------------|
| 1. Motor Set | 10. Front Radar/Bracket |
| 2. Drone Arm | 11. RTK Module |
| 3. Front Cover | 12. Front Board |
| 4. Gimbal Camera | 13. FC Module |
| 5. Centrifugal nozzle | 14. RC Module |
| 6. Landing Gear | 15. PMU Module |
| 7. Lock | 16. Tank |
| 8. Receiver Antenna | 17. Tank Control Board |
| 9. GPS/Bracket | 18. Flexible Impeller Pump |

2.3 Remote Control

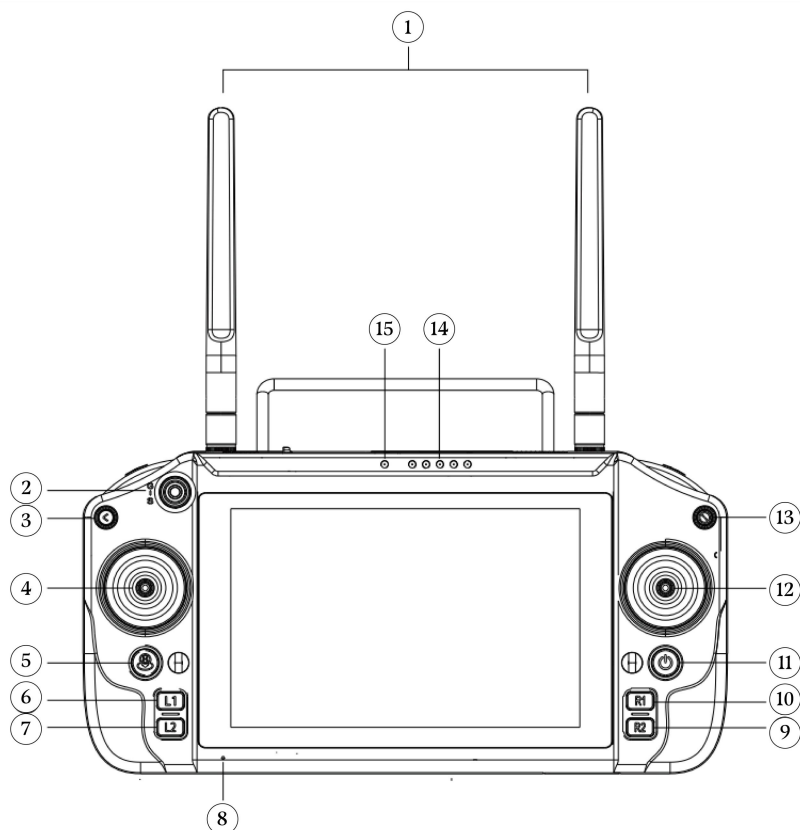

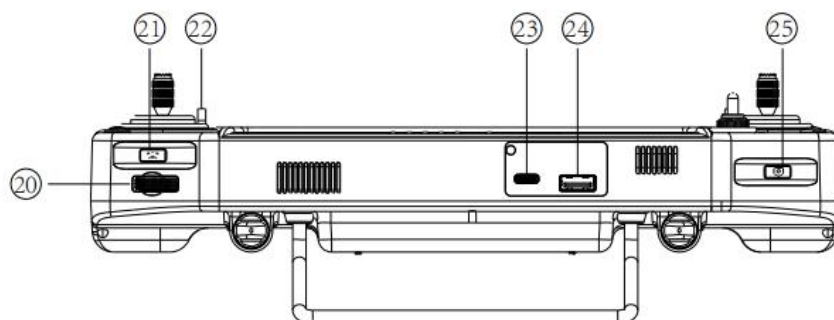
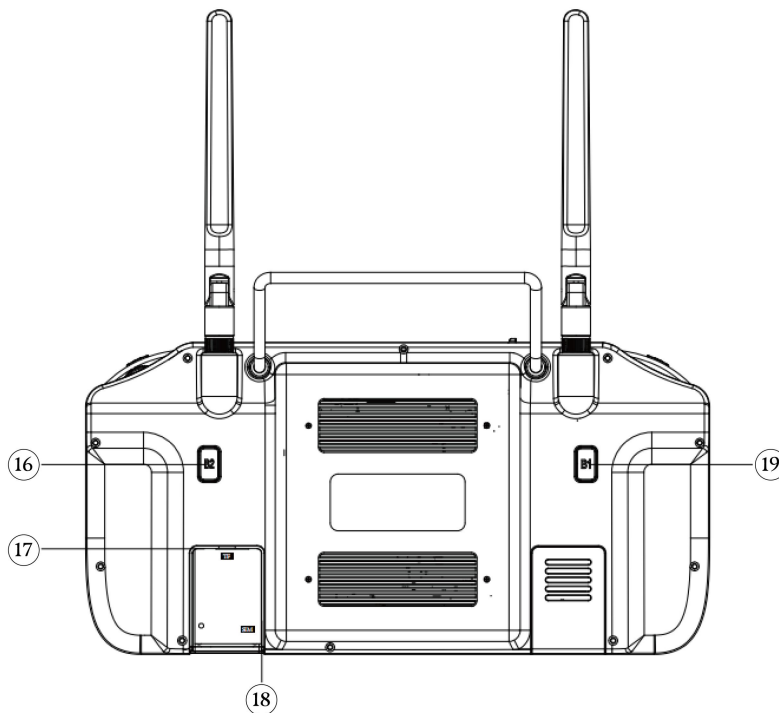

- | | |
|-----------------------------------|------------------------|
| 1. Antenna | 14. Power Indicator |
| 2. Wheel Switch(GPS/GPS/Attitude) | 15. Link Indicator |
| 3. Return Button | 16. B2 Button (Empty) |
| 4. Left Rocker X1、Y1 | 17. TF Card Slot |
| 5. H Button (Home) | 18. SIM Card Slot |
| 6. L1Button (Barrier) | 19. B1 Button (Empty) |
| 7. L2 Button (Terrain Following) | 20. Gimbal Pitch |
| 8. Microphone | 21. Valve/Pump Switch |
| 9. R2 Button (None) | 22. Lanyard Hole |
| 10. R1 Button (None) | 23. TYPE-C Port |
| 11. Switch | 24. USB Port |
| 12. Right Rocker X2、Y2 | 25. Disc/Nozzle Button |
| 13. Pause Button | |

2.4 Battery

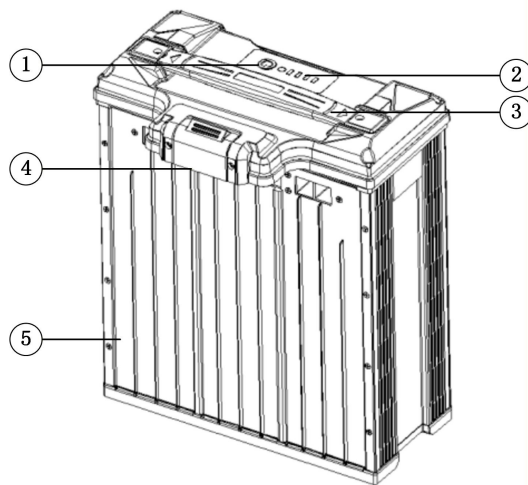

① **Power switch**

Short press to check the battery power. Short press then long press to power on. **Please make sure battery is inserted before power-on, and power off the battery before remove it or it may damage the drone and interface.**

② **LED Indicator**

Shows the battery level.

③ **Handle**

For lifting the battery.

④ **Power Interface**

For charging and discharging.

⑤ **Protective cover**

For protecting battery.

2.5 Charger

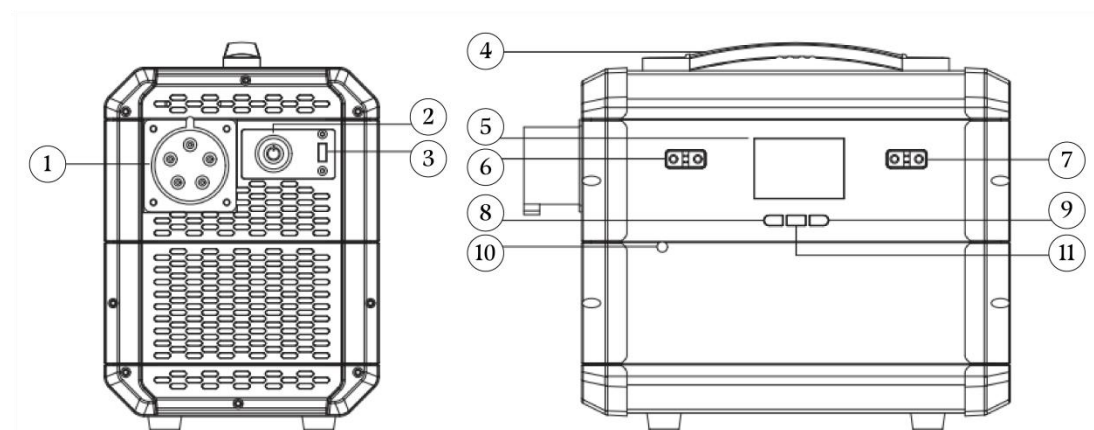

1. AC Input Port
2. Power Switch
3. USB Upgrade Port
4. Handle
5. Screen
6. Channel A
7. Channel B
8. Button (Power+)
9. Button (Power-)
10. Ground Screw
11. Button (Pause)

3 Flight Preparation

3.1 Device Activation

3.1.1 Account Registration

- Step1: Turn on the remote control first, then power on the drone;
- Step2: Open Flight Assistant APP, click **Accounts**, register by filling in information as required (using phone or email to register). Or directly log in exist account.

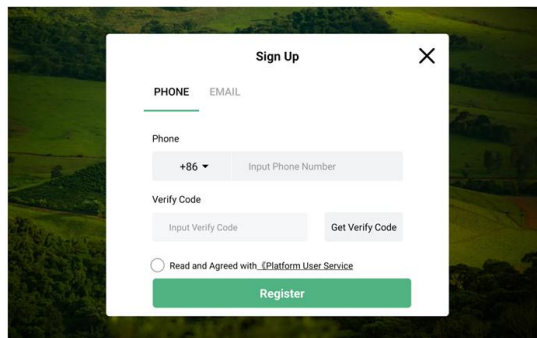
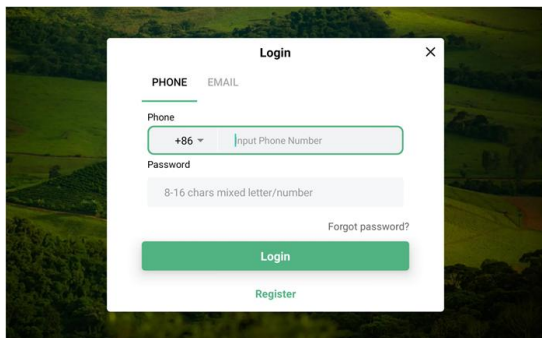

3.1.2 G20 Binding

- Step1: Open the G20 Device Assistant APP and click **WIRELESS PARAMETER CONFIGURATION**. It will show Not Connected. Open the front drone cover, long press the receiver button on the front PDB until the indicator light flashes. Click **START FREQUENCY MATCHING**, after successfully matching, it will display **Connected**.

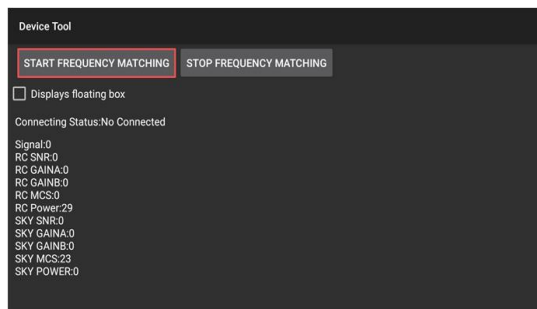
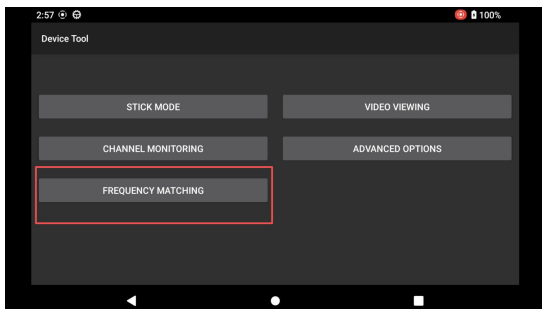

- Step2: Click **ADVANCED OPTIONS**, enter the password 999, click **BAUD RATE SETTING**, set the UART0 — 115200, then click **SAVE SETTINGS**.

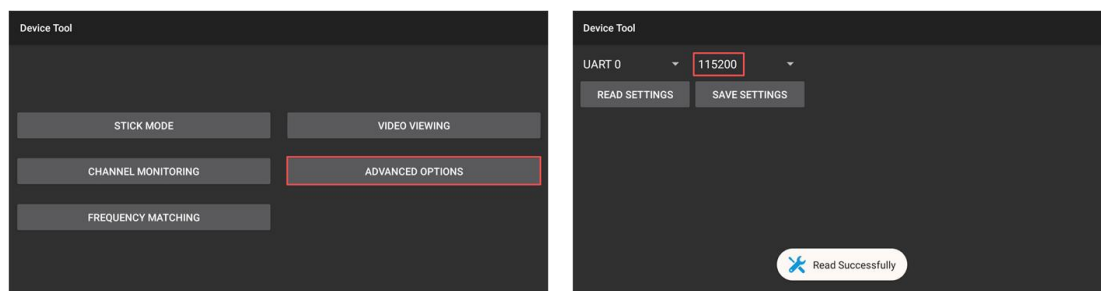

- Step3: Close G20 Device Assistant APP,open Flight Assistant APP. The **Connected** indicates the remote has been matched with the drone successfully.

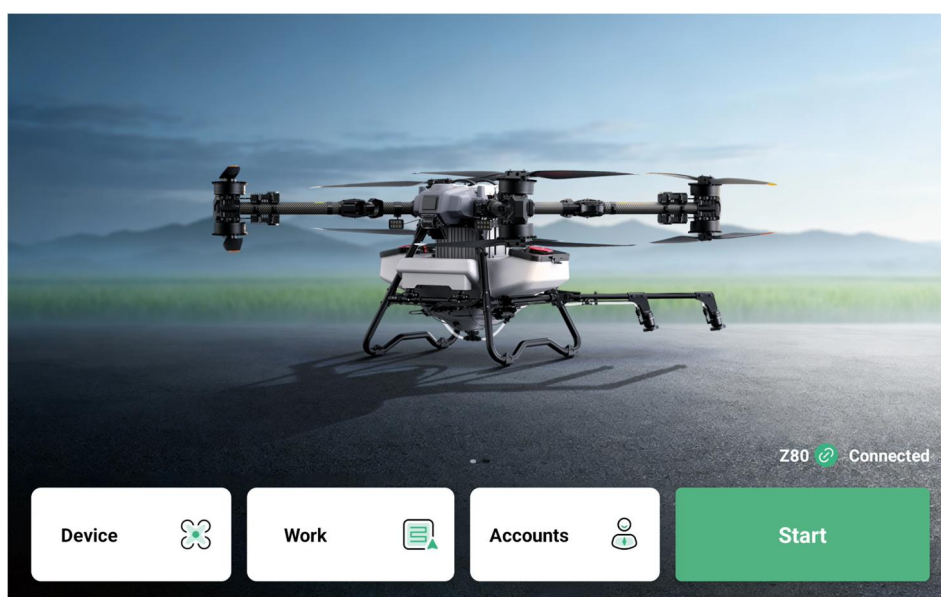

3.2 Operating Environment

- 1) Please pay attention to obstacles such as electric poles, high-voltage wires, buildings and trees when takeoff, landing and flight, and ensure fly within the visual range and away from roads, water, people and livestock;
- 2) Maintain more than 5 meters away from the drone when taking off;
- 3) Do not fly in bad weather, such as strong winds (wind speed 6 m/s or above), rain (rainfall 25 mm or above in 12 hours), snow, ice, fog, lightning and other extreme weather;
- 4) Do not take off on gravel-covered ground to prevent gravel from entering the motor and causing failure;
- 5) Do not operate indoors, under bridges, or other places where GNSS signals are severely blocked. Ensure that the GNSS signal is good during operation;
- 6) There should be no electromagnetic interference such as high-voltage lines, communication base stations or transmission towers in the operation area and nearby;
- 7) It is recommended to choose an altitude below 1km during operation.

3.3 Pre-flight Inspection

- 1) Ensure that no non-EFT official accessories and loads are installed on the drone;
- 2) Ensure that the batteries are fully charged, and the pesticides required are sufficient;
- 3) Ensure that the battery and tank are installed in place;
- 4) Ensure that the motor and propeller are installed correctly and firmly, and the propellers are not deformed, damaged, or aged; the motor and propellers are clean and free of foreign matter, the propellers and arms are fully unfolded, and the arm buckles are locked;
- 5) Ensure that the remote control antenna is unfolded;
- 6) Ensure that the arrow on the GNSS points to the front of the drone;
- 7) Ensure that all components are installed firmly;
- 8) Ensure that all cables are correct and firm;
- 9) Ensure that the surface of the gimbal and radar is clean and unobstructed;
- 10) Ensure that the spraying pipe is not blocked or leaking;
- 11) Connect the remote control to the local area network. Check if the APP version and flight control firmware are the latest in Flight Assistant APP, if not, it is recommended to upgrade before operation.

3.4 Calibration

3.4.1 Controller Calibration

- Step1. On the Flight Assistant app, tap **Start**, then tap the Settings . In Controller page, tap Calibrate to enter the calibration page.
- Step2. Then move the left and right joysticks to the full extent.(The interface displays the stick movement range.) Repeat this step twice;
- Step3. After completing all the above actions, click **Confirm**.

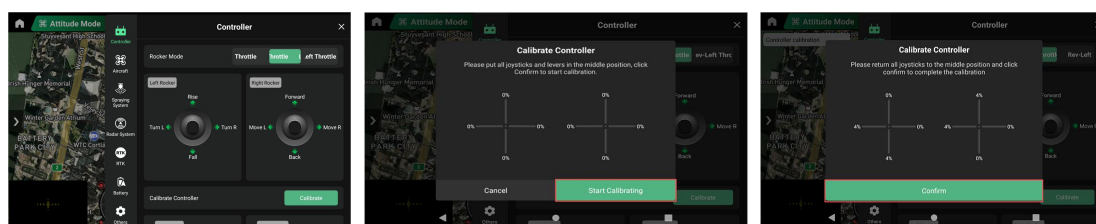

3.4.2 Magnetic calibration

Enter Settings  -**Flight -Sensor calibration-Magnetic calibration**; According to the prompts to complete the calibration then place the drone on the ground and Confirm. Please power off and then restart it for normal operation.

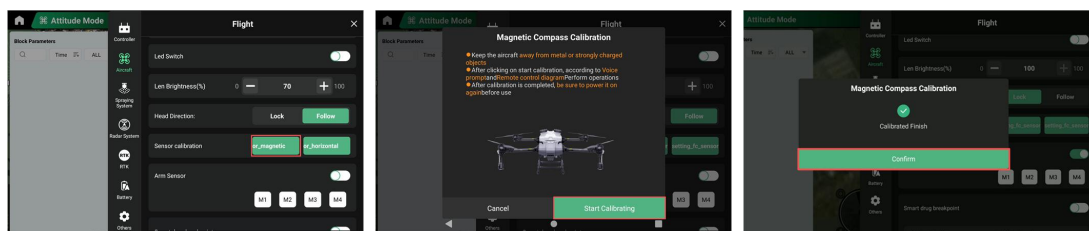

- * Do not calibrate in ferromagnetic areas , such as electric poles, walls with steel bars, etc.
- * Do not carry ferromagnetic materials, such as keys, mobile phones, etc. during calibration;
- * If the work site is more than 50 kilometers away from the calibration site, recalibration is required.
- * With an RTK module installed, compass calibration can be skipped.

3.4.3 Horizontal Calibration

Before starting calibration, place the drone on a level surface. Open the Flight Assistant app, go to Settings , and enter Flight Settings. Under **Sensor Calibration**, tap **Horizontal Calibration**. When the app indicates that calibration is complete, tap Confirm to finish the process.

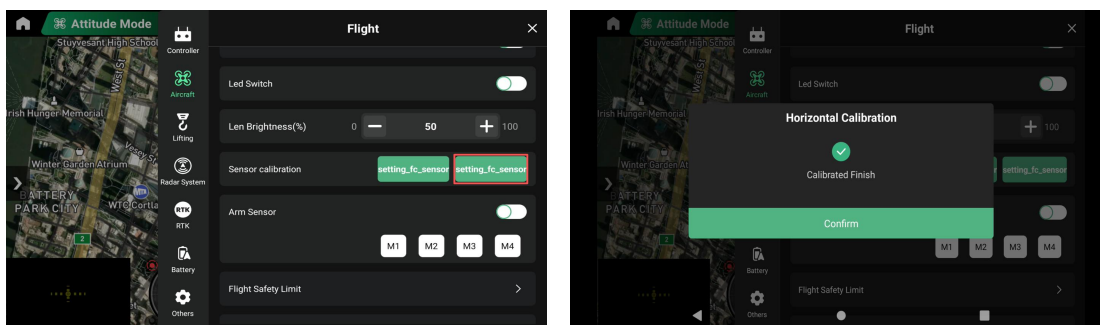

3.4.4 Weight Calibration

- Step1. In Flight Assistant APP, Settings -Spray Settings.
- Step2. Click **Weight calibration-K Calibrate**,check if all the K values same as the numbers on the weighing module. If not, please modify it accordingly.

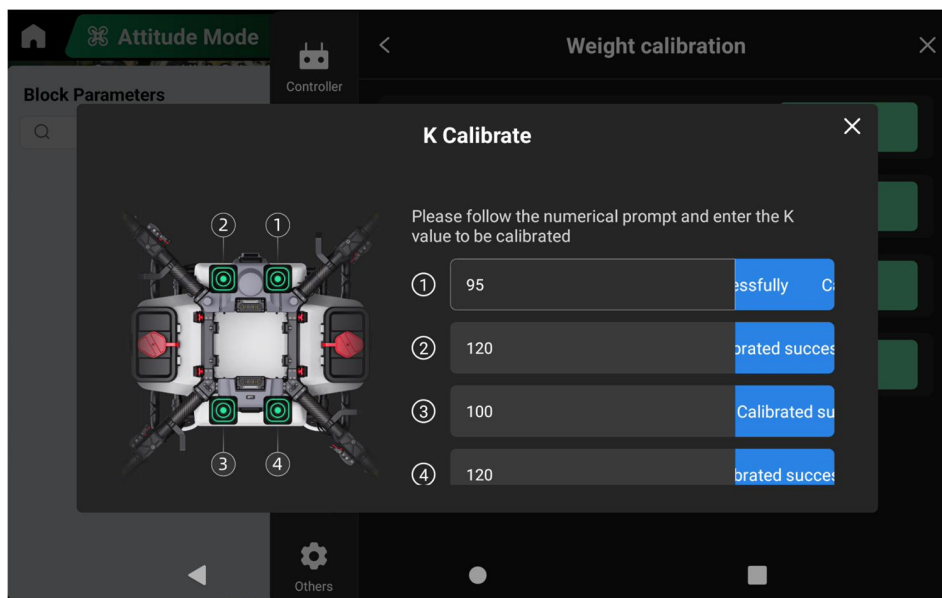

- Step3. After completing the K calibration, tap **Zero Calibration** and check if the weight in the app reads 0.
- Step4. Weigh more than 40kg materials and record the weight, pour them into the tank. Then tap **Weight Calibrate**, input the recorded weight. If the number on the app matches the input one, then the calibration is succeeded.



* During the calibration, ensure no foreign objects on the tank and the tank tightly fits the weighing sensor without any gaps. And do not touch the tank.

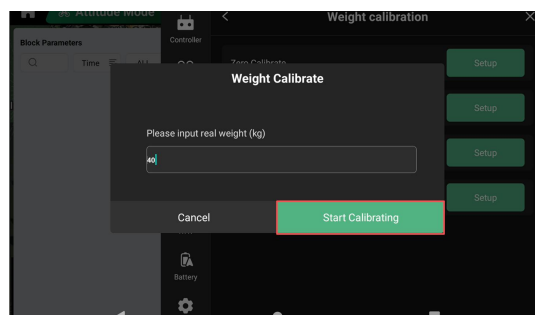
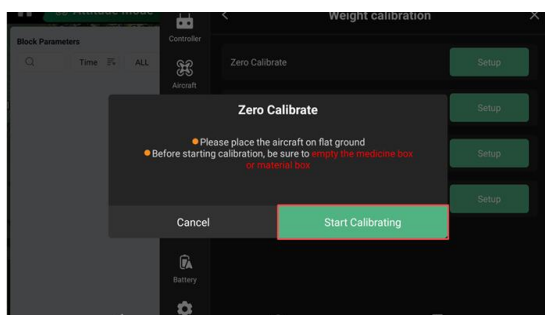

3.4.5 Pump Calibration

Before the first spraying operation, the water pump must be calibrated. The operator needs to calibrate the left and right pumps separately.

Dual-Pump Calibration:

- Step1. Add at least 60 L of water to the tank. Turn on the pump to purge air, then turn it off.

- Step2. Tap to go to Spraying System Settings, then tap **Spray Calibration-Pump**, select **Left Pump** and tap **Start Calibrating**. After the left pump is calibrated, select **Right Pump**, and tap **Start Calibrating**. Keep the tank filled with water throughout the process. When the App shows calibration complete, tap **Confirm**. The page will then automatically display the calibrated pump values. Ensure the maximum and minimum flow rates are within the normal range.

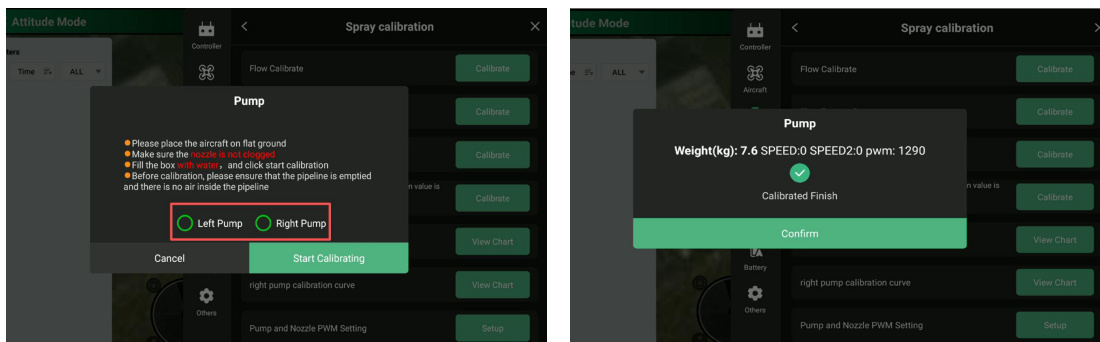

After calibration, left and right pump curves are generated and can be viewed.

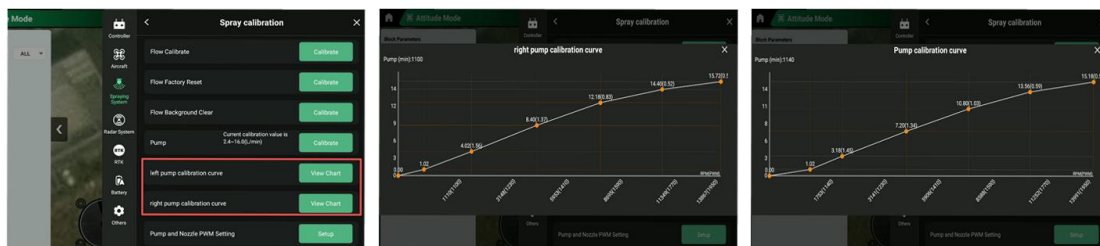

3.4.6 Spreader Calibration

When switching to spreading mode, the app will detect and display it automatically.

Do not plug or unplug wires while powered, and keep connectors dry.

After switching modes, redo **Zero Calibration** and **Weight Calibration**.

Before automatic spreading, complete spreading calibration and select the correct template. Steps are as follows:

- Step1. Add more than 50kg of materials in the spread tank, then raise the drone, remove the spreader, and place a container under the spreader outlet to catch the discharge.
- Step2. Click setting button-**Seed System-Seed material management-Add Calib**, fill in the material name and click **Confirm**.
- Step3. The drone starts automatic calibration. After the calibration, App page will shows calibration completed. Click **Confirm**.

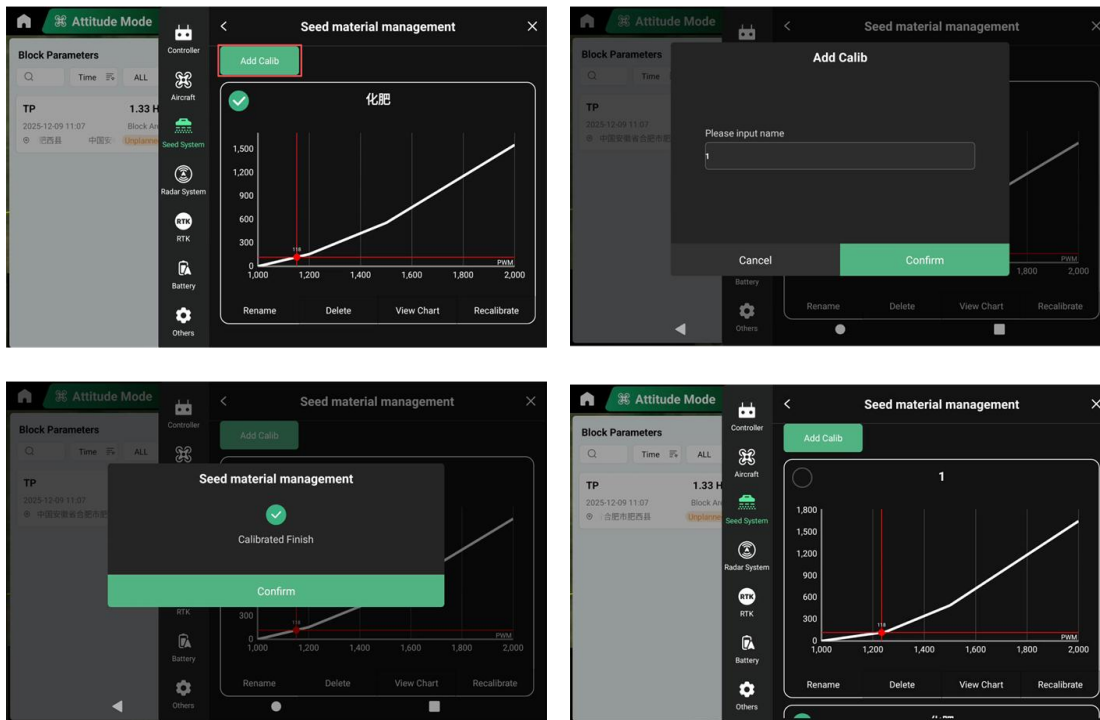

*After calibration, a curve will be auto-generated. Before spread, just need chose proper curve according to the seed, or choose the appropriate calibration curve in the operation parameter settings.

3.4.7 Voltage Calibration

Tap to view and configure battery parameters. Recommended low power alert threshold: 30%, action: Warning. Recommended severe low power alert threshold: 20%, action: Home.

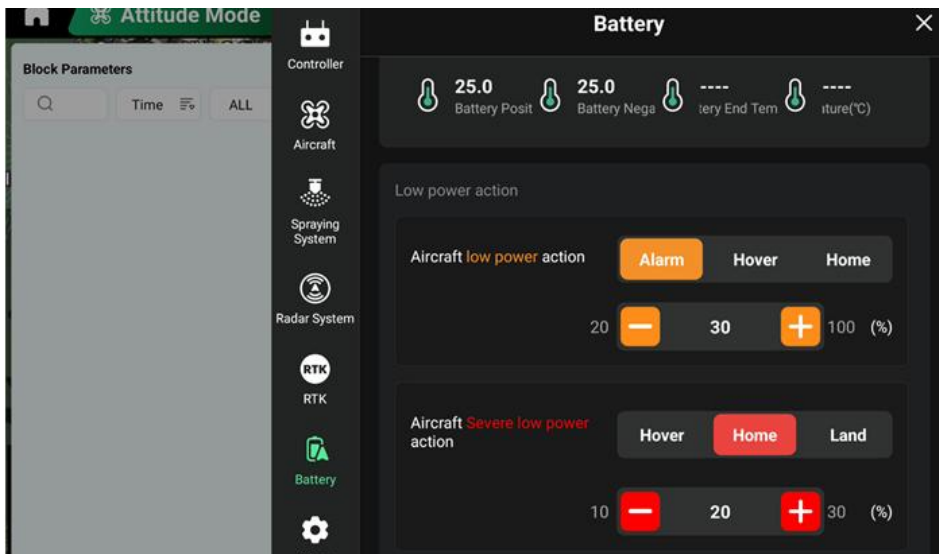

*If the battery voltage does not match the app reading, disconnect the battery signal cable.



Then tap Voltage **Calibrate**, enter the actual voltage, and tap **Confirm** to complete the calibration.

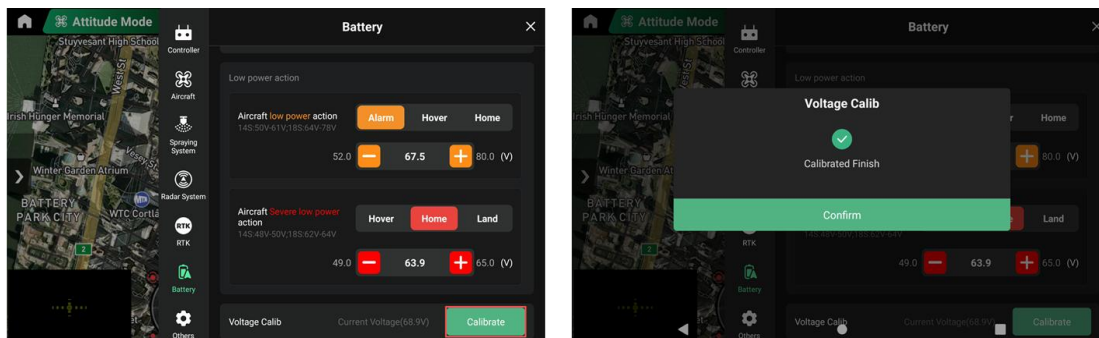

3.5 Flight

- 1) Place the drone in an open area with the user facing the tail of the drone;
- 2) After adding materials to the tank, tightly close the lid;
- 3) The user must wear a helmet, and people must keep a safe distance of more than 5 meters to the drone;
- 4) Turn on the remote control first, then install and turn on the battery. Connect the drone to the remote control;

* If connection fails, re-link is needed: Open the G20 APP and click **FREQUENCY**



MATCHING. It will show **Not Connected**. Open the front drone cover, long press the receiver button on the front PDB until the indicator light flashes. Click **Start Matching**, after successfully matching, it will display **Connected**.

- 5) Confirm that the rocker mode fits the use habit. (the default setting is Left throttle);
- 6) If using RTK , select the correct RTK signal source. In APP - Settings -RTK Station, and select proper data source;
- 7) Search for satellite: ensure GNSS signal is good, open the antennas and start the motor. If app shows RTK antenna is not ready after a long while, then move to an open area with good GNSS signal;
- 8) Start the motor: turn the rockers inward or outward for 2 seconds to unlock the motors. Once motors start, release rockers immediately and takeoff as soon as possible. If takeoff is not available, do not start the motor;

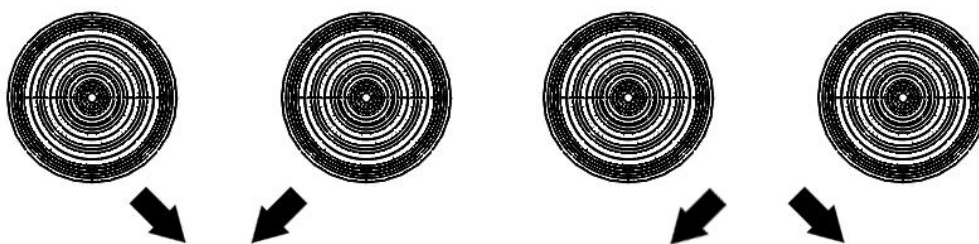

- 9) Stop the motor: Pull down the left rocker (in Left throttle) to land the drone. After landing on the ground, pull the left rocker to the lowest position and keep it still for 3 seconds to stop the motor.

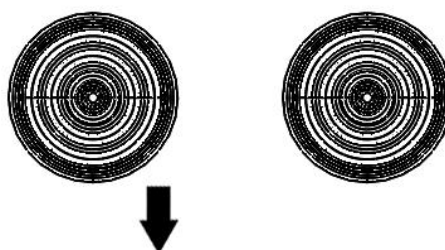
**Shutdown in mid-air:**

When an emergency occurs in the air, to prevent possible danger, turn the rockers inward or outward for 3 seconds, the motor will stop running immediately and the drone will fall to the ground.

* During the flight, do not stop the motor at will, otherwise it will crash. Unless there is an emergency (such as the drone may crash into a crowd), use the shutdown to minimize damage.

* After the drone lands, please turn off the battery first, then turn off the remote control.

4 Drone Operation

4.1 Remote Control

4.1.1 Remote Control Gear

There are two flight gears: GPS and Attitude. GPS is used by default. If Attitude Mode is available in APP, then you can switch mode by gear.

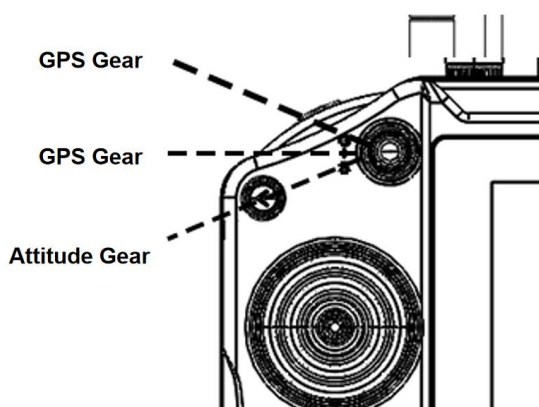

GPS position: Precise hovering and positioning, achieving centimeter-level positioning with RTK.

Attitude position: No fixed-point hovering, only attitude stabilization. The flight speed in this mode is related to environmental factors such as wind speed.

Default gear is GPS. If need attitude mode, in APP-click setting button —flight safety- switch on **Attitude Mode** switch, then move the gear to Attitude mode.



Precautions for Attitude Mode

In Attitude mode, the drone cannot be position and greatly hard to be operate. Using this mode requires operator to excel in drone control. Do not fly too far to prevent lose control and cause hazard. And try to avoid flying in area with poor GNSS signal, obstructions (such as tall buildings), and narrow spaces, so as not to passively start Attitude mode and cause accidents.

4.1.2 Rocker Mode

In Flight Assistant App, click **Start-Settings** , the Rocker mode includes Right throttle, Left throttle and Rev-Left throttle.

Right Throttle

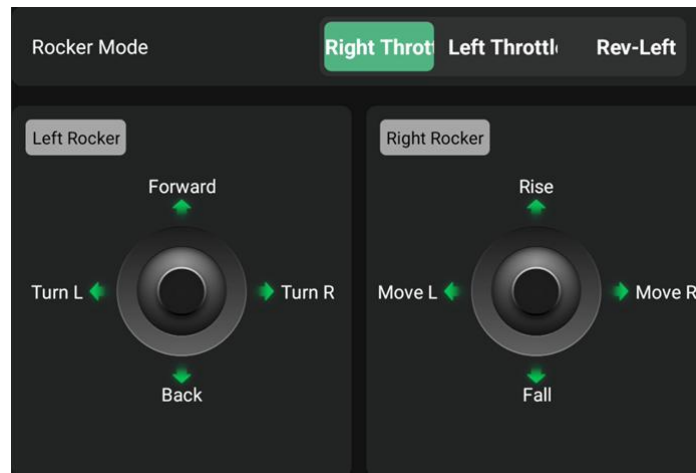

Left Throttle

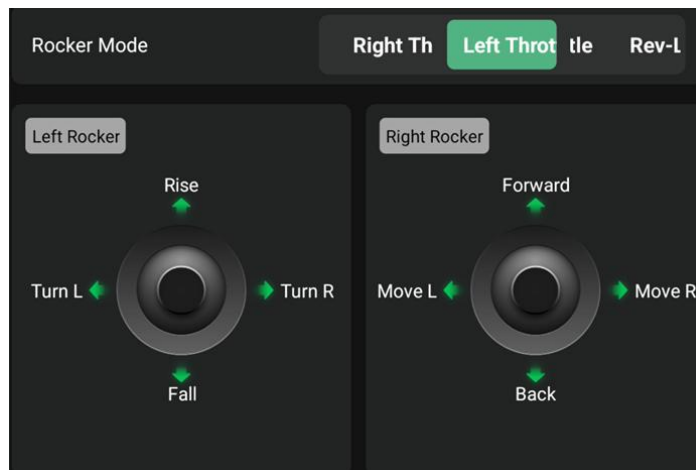

Rev-Left Throttle

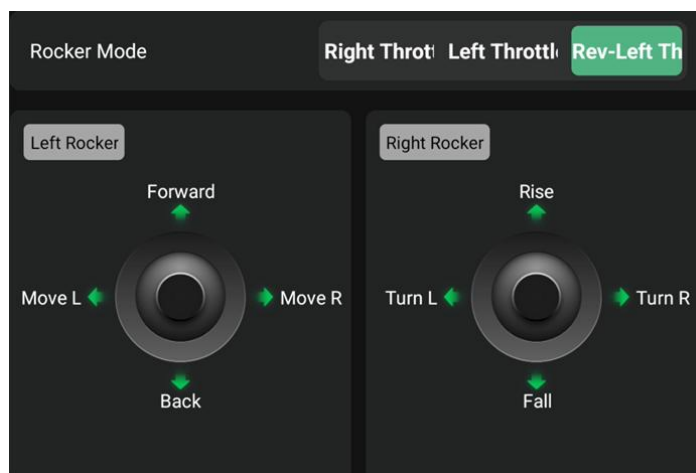

 This manual uses the Left throttle as an example to explain the remote control operation method.

4.1.3 Homepage

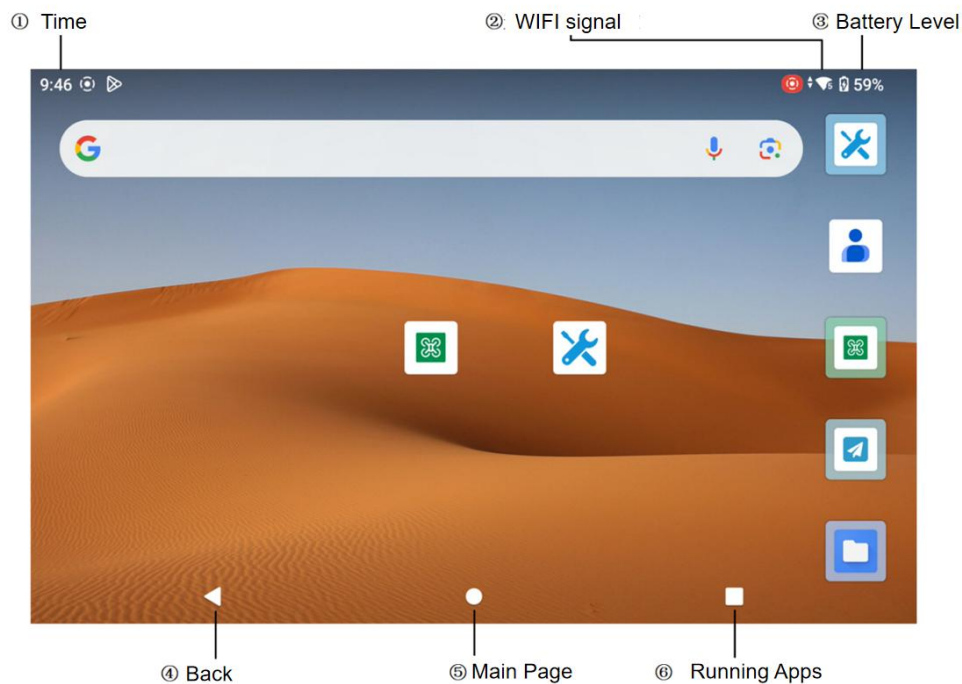

4.1.4 G20 Device Tool APP

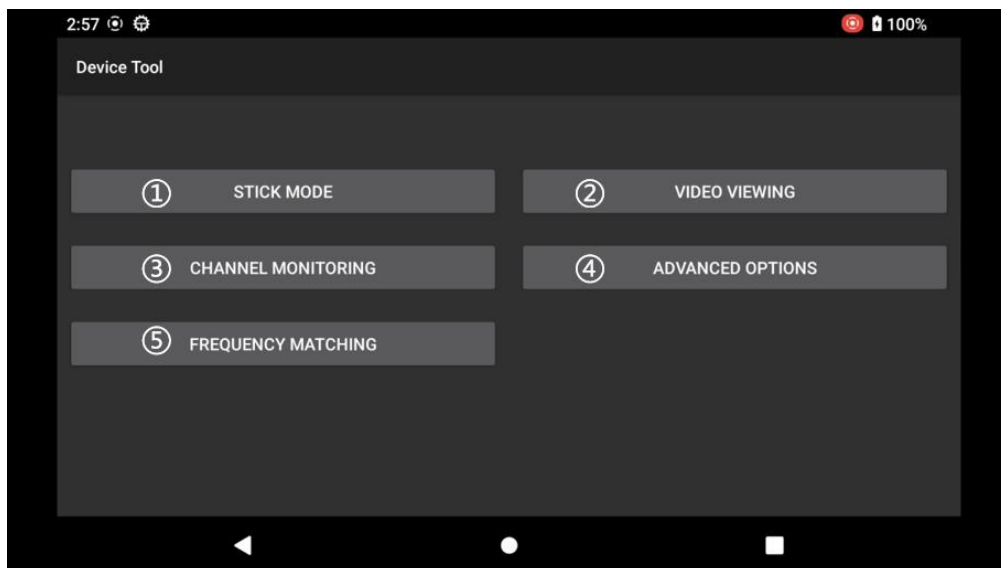

- ① **STICK MODE**
Choosing stick mode.
- ② **VIDEO VIEWING**
Check camera images.
- ③ **CHANNEL MONITORING**

Check whether the joystick servo values of the remote controller are normal.

④ **ADVANCED OPIONS**

Adjustable channels, remote controller firmware upgrade, button configuration, relay mode setup, and receiver serial port baud rate settings. The baud rate is fixed at 115200 (password: 999, for professional use only).

⑤ **FREQUENCY MATCHING**

Used for binding the remote controller to the receiver and check signal quality.

4.2 APP Overview

Flight Assistant APP is designed for agricultural application. Users can control and view the operation status of flying, spraying and spreading in real-time . Get data of the radars, water pumps, and flow meter etc . This APP is smart operating system, User can set Intelligent route planning to enjoy efficient intelligent operations.

4.2.1 Homepage

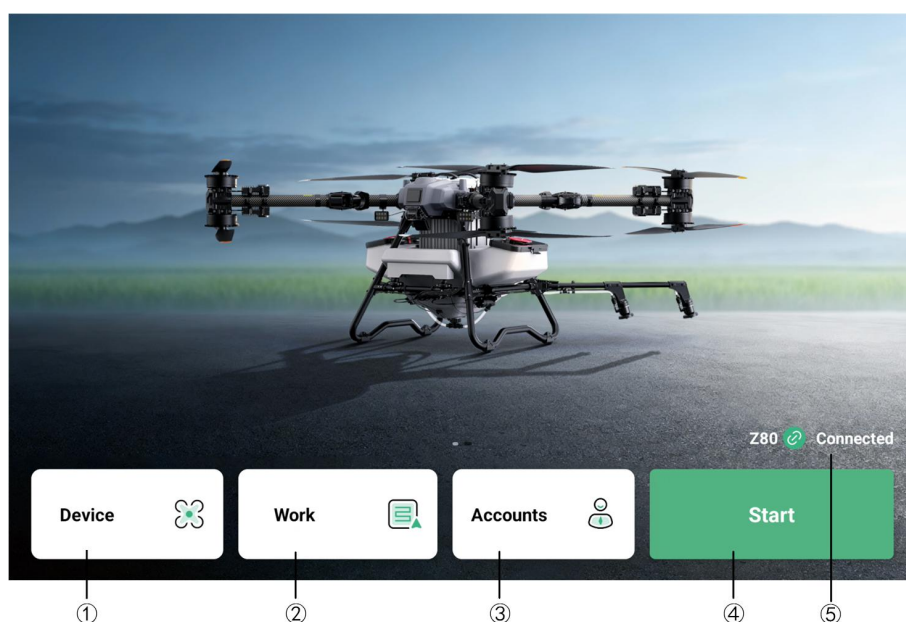

① **Device**

View device connection status, flight controller SN and firmware, and firmware updates for the flight controller, radar, and other devices. (Grey icons indicate unavailable functions.)

② **Work**

View fields, flight data, teams, and devices.

③ **Accounts**

View user info, flight and lifting records, logs (download FC and app logs), general settings, and account security.

④ **Start**

Tap to enter the operation page.

⑤ Connected

Shows connection status. If the remote controller is bound and the baud rate is 115200, the device connects automatically after power-on. If “Disconnected”, bind the device in Device → Remote Controller.

4.2.2 Start the operation



① Home

Back to Homepage.

② Connection/Flight Mode

Display the drone status. Tap  to check alarms: If there is a alarm, tap to view the detail information and solve it accordingly before flying.

③ Flight Time

The time of each flight is recorded and recalculated when landing.

④ Signal

Communication status between the remote control and the drone.

⑤ Battery Level

Display the battery level (smart batteries show battery percentage, others show battery voltage).

⑥ GPS/RTK Connection

Display the positioning mode.

⑦ Spray/Spread/Lift

Automatically identify operating modes.

⑧ Operation Mode

Manual mode, AB mode and Auto mode are optional.

⑨ Settings

Set the parameters of drone and remote control.

⑩ Location

Locate the real-time positions of the remote control.

⑪ **Drone Position**

Directly locate the real-time position.

⑫ **Visible/Hide**

Click to show or hide the radar ball, aircraft and operation status parameter.

⑬ **Eraser**

Clear the flight trace.

⑭ **Area Data**

Real-time display of the current route area and the work area.

⑮ **Add Block**

Add the new block.

⑯ **Edit**

Plan flight routes of the block.

⑰ **Edit Parameters**

Set operating parameters.

⑱ **Start Work**

Tap to start work.

⑲ **Flight and operations real-time data**

Speed: Drone real-time flight speed.

Dist: The real-time horizontal distance between the drone and the home point.

Height: If the altitude radar is turned on, displays the relative height of the drone and the object below. If turned off, it displays the relative height of the drone and the take-off point .

Area: Display the real-time operating area of one single flight.

Drug (Spray) : Display the weight of pesticide sprayed during spraying.

Valve Size (Spread) : Display the real-time opening of the spreader valve during spreading.

Flow (Spray) : Display real-time spraying flow.

Turntable Speed (Spread) : Display real-time spreader turntable speed.

Weight: Display the remaining weight in the spraying tank/spreading tank.

⑳ **Radar**

Detect and display vertical obstacles. Tap the icon to turn on or off the obstacle avoidance functions.

㉑ **Images**

Show the real-time camera view, can be switched to full-screen display.

㉒ **Block Parameters /Route Parameters/Working Parameters**

Tap to expand the list and set the speed,width or other parameters.

4.2.3 APP Settings

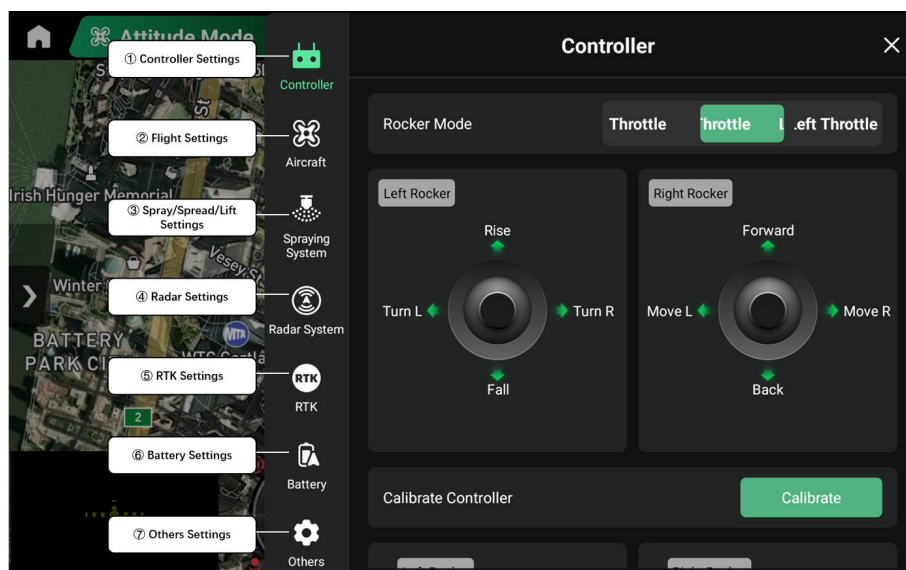

① Controller

Choose rocker mode, calibrate controller, set channels.

② Aircraft

Include flight parameters, Sensor Calibration, Arm Sensor, Smart Drug Breakpoint, Flight Safety Limit and Flight Simulator.

③ Spray/Spread/Lift Settings

Spray/spread/Lift system related settings, including switch, data and calibration.

④ Radar System

Include switch of obstacle radar, Terrain radar, Obstacle Dist, Obstacle Avoidance Action and Radar Sensitivity.

⑤ RTK Settings

Include RTK Network, Station Custom and Status.

⑥ Battery Settings

Include Low power action, Alarm threshold value, and battery information.

⑦ Others

Includes voice prompts, device checks, advanced settings, and camera types.

4.3 Operation Mode

4.3.1 Add Block

In Flight Assistant APP—Start— Auto Mode, tap **Add** to plan a new block. Tap  to choose Mark(Drone), Mark(Map) or Mark(RC).

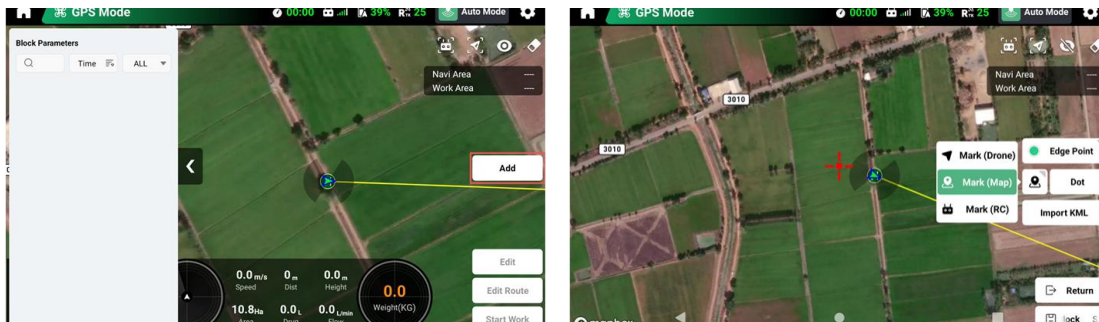

- **Mark(Map): Suitable for terrain with regular plots and clear display on the map.**
Tap **Mark(Map)—Edge Point**, Find the specified plot on the map, move the cursor to the boundary of the plot, tap **Dot** to set the **Edge Point** in turn to complete plot mapping . Then tap **Save Block**, fill in the relevant information as required to save it.
- **Mark(Drone): Suitable for terrain with regular plots but not clear on the map.**
After tapping **Mark(Drone)** , fly the drone to the desired plot edge, tap **Dot** to mark points around the plot, and tap **Save Block**. Then fill in the relevant information as required to save it.
- **Mark(RC): Suitable for irregular plots with obstacles.**
After tapping **Mark(RC)**, walk to the edge of the plot with the remote control, tap **Dot** to mark points around the plot, and tap **Save Block**. Then fill in the relevant information as required to save it.

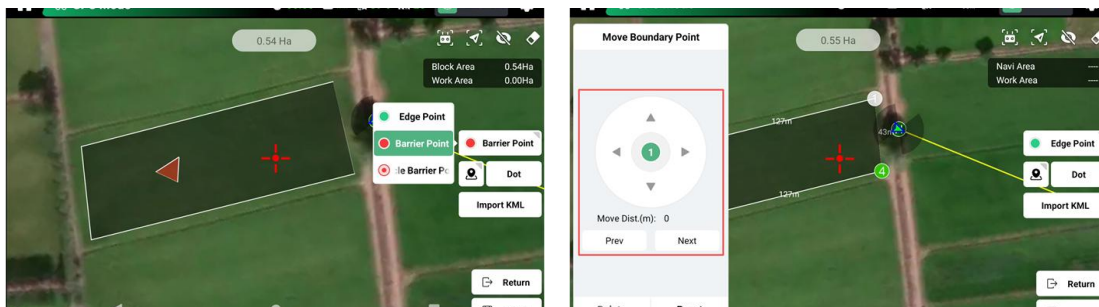

- **Obstacle Point Marking: Suitable for fields with obstacles.**
Tap **Edge Point-Barrier Point** and mark obstacles on the map to create an obstacle area, or select **Circle Barrier** for automatic generation. Flight routes will automatically avoid these areas. Tap **Save** and enter the required information to save the block.

If you need to modify a marked point within the block, tap the corresponding point number on the map. After selecting it, a **Move Boundary Point** pop-up will appear, where you can edit or delete the selected point.

KML File Import

- **Import KML: Users can import KML files as needed, and the app will automatically generate the corresponding field.**
- Step 1: Download the prepared KML file to the **Download** folder on the remote controller.
- Step 2: On the **Add** page, select **Import KML**, then choose the KML file from the file directory.
- Step 3: The app will automatically generate the field. Users can directly edit the field or route.

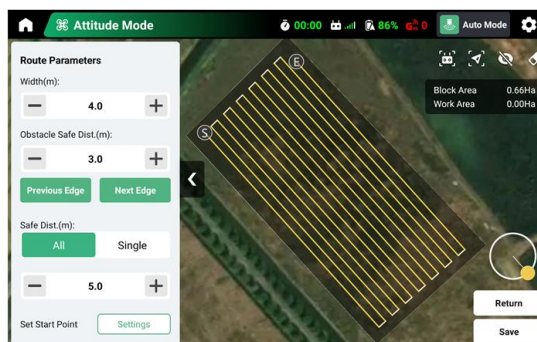
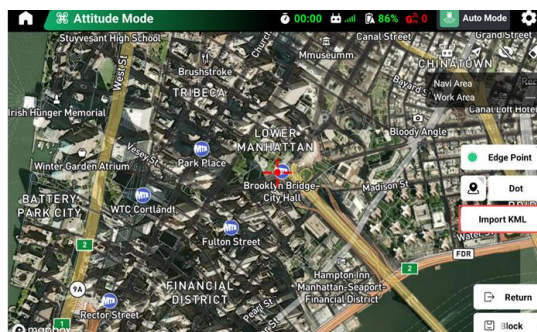
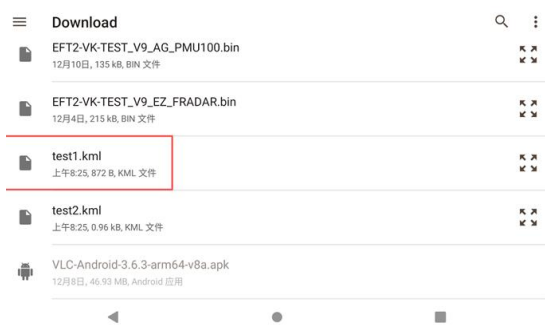

Route Parameters

- Step 1: Select the block from the parameter list. The options allow you to rename, split, or delete the block.
- Step 2: Tap **Edit** to modify the block. The operation steps are the same as those used in field planning.
- Step 3: Tap **Edit Route**. The system will automatically generate a flight route for the field. In the pop-up panel, you can set the route parameters. After completing the settings, tap **Save** to save the route and related parameters.

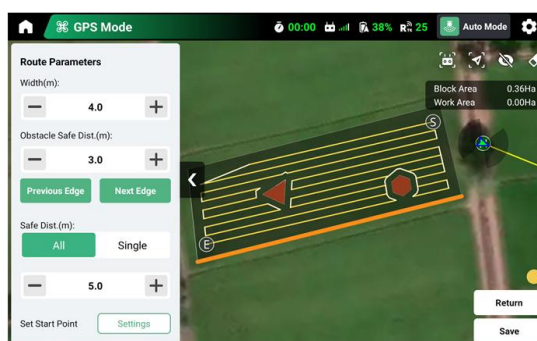
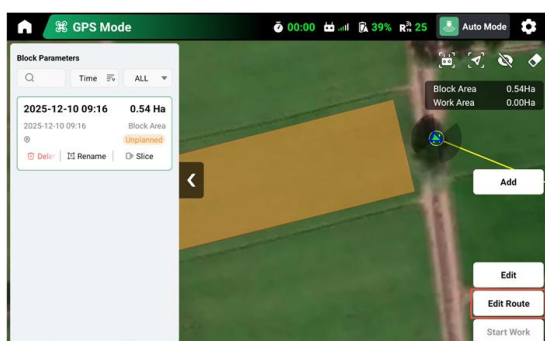

Work Parameters

After saving the route parameters, the **Work Parameters** list will pop up automatically. There are **Fixed** and **Dynamic** for spray mode, and you can set the **Spray quantity** and **Nozzle speed**, or you can call saved template.

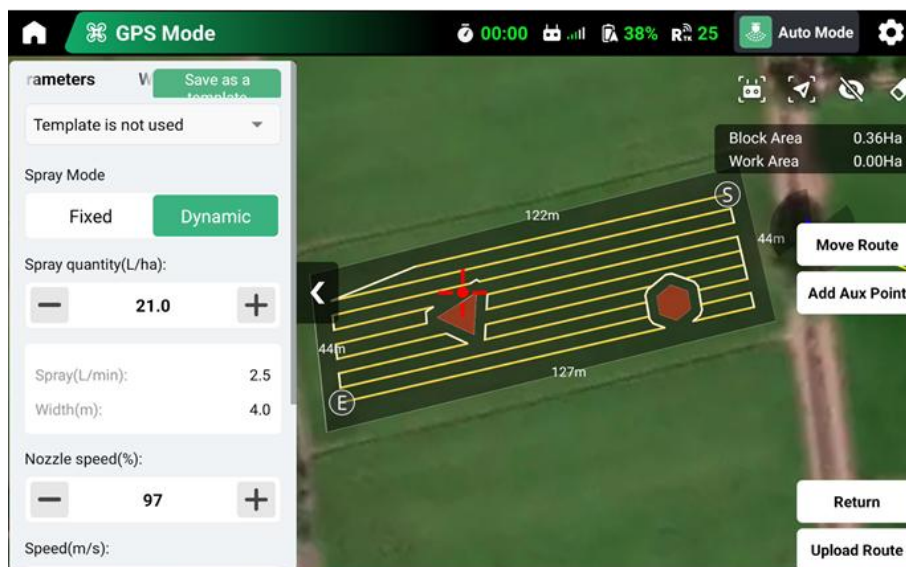

Start Work

After setting the work parameters, tap **Upload Route**, then tap **Work**, a pop-up window **Flight Confirm** will appear, then confirm the flight information. Then slide the indicator bar, the drone will automatically take off, or manually fly the drone to the area near the start point and then slide to start, then the drone will automatically fly to the start point (S) to work.

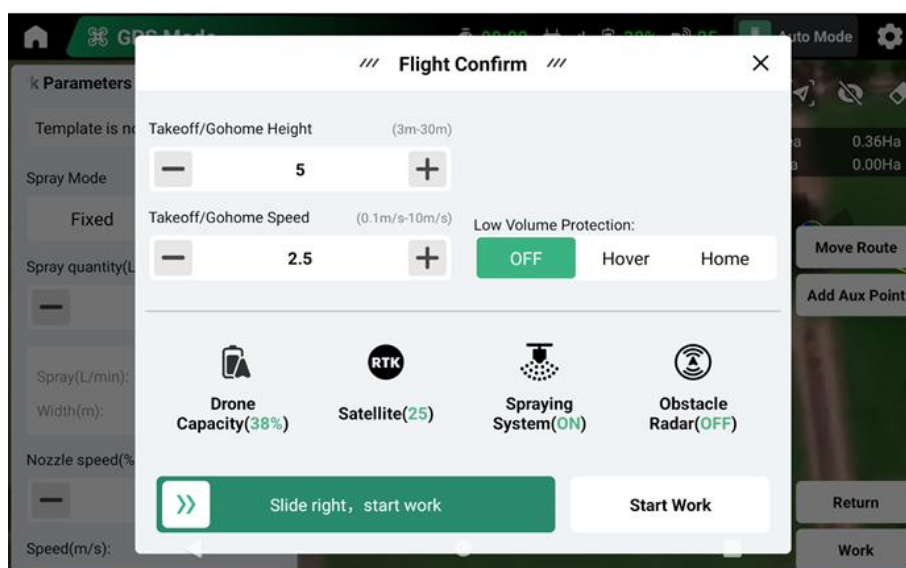

4.3.2 AB Mode

- Step1. In Flight Assistant APP, select **Spraying- AB Mode**; Select **Fixed** or **Dynamic** for Spray Mode.
- Step2. Set the parameters or save as template for next call.
- Step3. Fly the drone manually to the block starting point (with pesticide in tank), clicks A on the APP to mark point A.

- Step4. Then fly the drone to the other end of the plot (pump and nozzle will open automatically), then click B to mark point B.
- Step5. After marking A and B, the right flight route will be generated automatically . Click Direction swi to switch direction to left.
- Step6. After confirming the route, click **Work** and slide to start work. The drone will spray automatically along the routes.

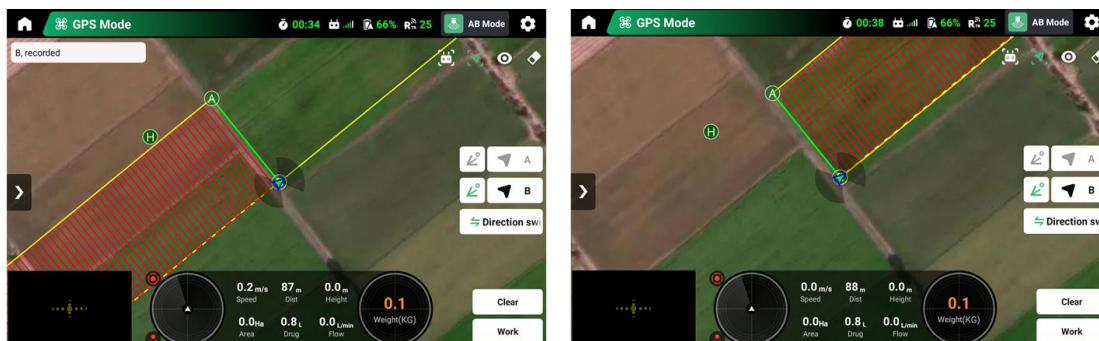

- Step7. If the area is irregular, adjust the drone heading to change the working area. After setting the drone heading, tap Note: Adjust the heading after recording point A or B.



AB mode is suitable for large, regular fields without obstacles.

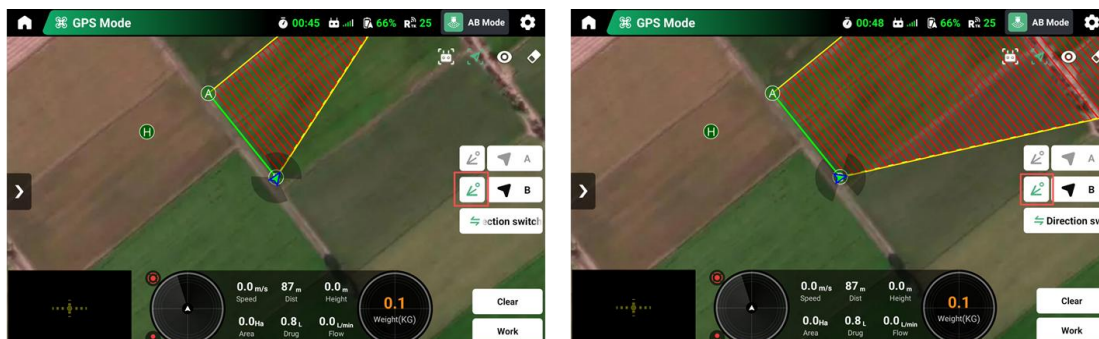

4.3.3 Manual Mode

- Step1. In Flight Assistant App, choose **Spraying-Manual Mode**;
- Step2. Tap to expand **Work Parameters**, Select **Fixed** or **Dynamic**, then set spraying parameters, or directly call the saved operation template.
- Step3. The user flies the drone to the operation area, and then turn on the water pump to control the drone to operate.



This mode is suitable irregular areas or small plots.



4.3.4 Breakpoint Resume

If the drone operation is interrupted, the breakpoint (**Br**) is automatically recorded. To continue, Tap **Resume** in the APP and the drone will finish the remaining route. It is useful for refilling pesticide, battery replacement or obstacle avoidance. To end the operation, click **Finish** in the APP.



During the operation, the following operations will record breakpoints (Br):

- 1) Tap Pause or End in the APP;
- 2) The drone returns home in any way.
- 3) The remote control has a stick action on the pitch stick or roll stick;
- 4) The drone makes an emergency stop to avoid obstacles;
- 5) The flight reaches limit or nears no-fly zone.
- 6) No materials in the tank;

- 7) Enter the level-2 low-battery protection setting;
- 8) The remote control is disconnected from the drone;
- 9) The spraying/spreading devices have an abnormality;
- 10) The drone has an alert broadcast during the operation.

Continue the operation

When a breakpoint is recorded during operation, if user exits the APP and operates again, first select the block, and the last record will be auto displayed. Click **Start - Upload Route** to continue from the breakpoint. If no need to continue, click **Edit Route** and select **Confirm** in the pop-up window to restart the operation.

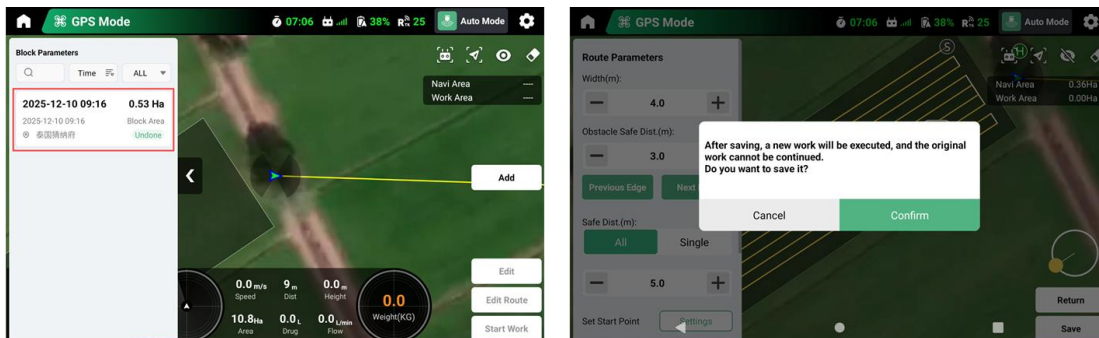

4.3.5 Manual obstacle avoidance

During operation, if an abnormal obstacle appears, please manually control to avoid it using the remote.



*In auto mode, if the drone encounters an obstacle, first tap Pause in the App, the drone will automatically switch to GPS mode and hover, then manually control it to bypass the obstacle, and the drone will enter the Projection mode, and (Break Point)/(Return Point 1)/(Return Point 2) will be automatically displayed on the screen. Click Breakpoint, the drone will automatically operate from the breakpoint; click ReturnPoint1, the drone will automatically operate from the point 1. If many obstacles ahead,click ReturnPoint2, then route between Point 1 and 2 will automatically turn green (operation finished) , drone will operate from point 2.

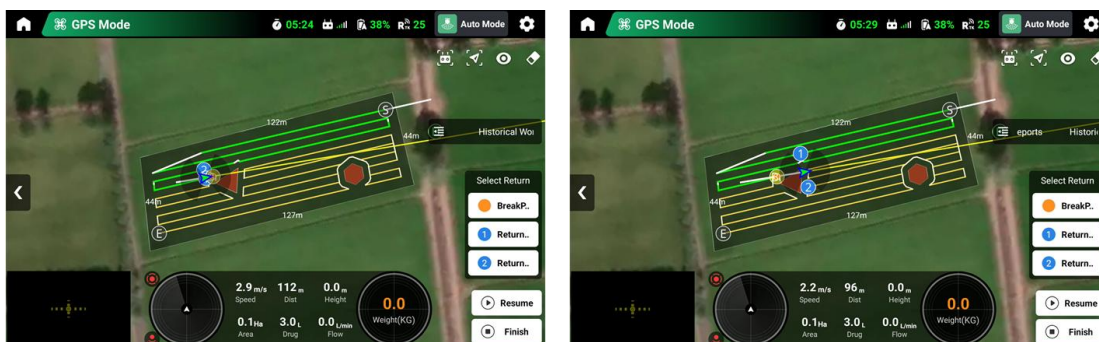

4.4 Spray/Spread Mode

The Z80 allows flexible switching between Spraying, Spreading, and Lifting modes. After switching, verify on the app's main operation screen that the correct mode icon is shown.

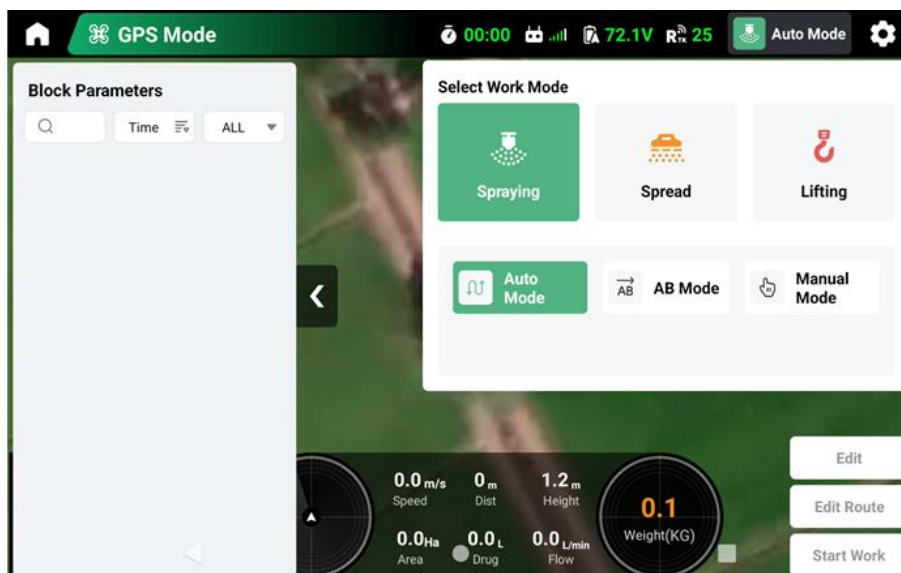

*When switching between Spraying, Spreading, and Lifting modes, do not plug or unplug connectors while the drone is powered on. Keep connectors dry. Weight calibration must be performed again after each mode switch.

*In Spreading Mode, complete spreading calibration before automatic operation. Select the appropriate template before starting the task.

4.5 Indicator Light Instruction

4.5.1 Motor Indicator Light

Drone arms M1 - M4 have LED lights. M1 and M2's red LEDs are nose indicators, always on during flight for nose direction. M3 and M4's green LEDs are tail indicators, always on during flight for tail direction.

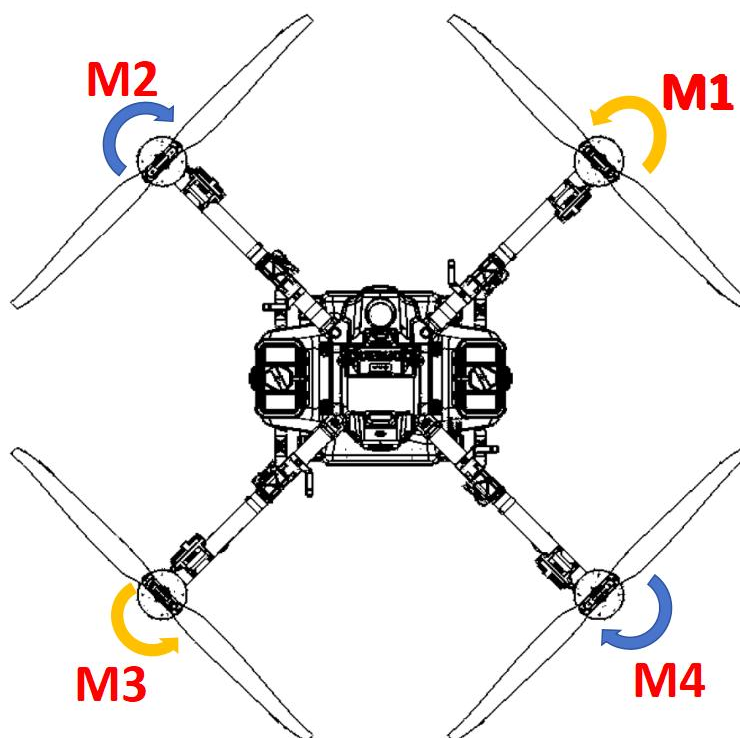





4.5.2 Motor indicator light Signals

Flashing color	Meaning	Solution
1 Short flash	Over voltage	Replace the battery (below 81V)
2 Short flashes (continuous)	Under voltage	Replace the battery (above 24V)
3 Short flashes (continuous)	Over current	Re-power on and check if any foreign object in themotor - Contact after-sales.
1 Single long flash (continuous)	Throttle lost	- Check the signal cable connection - Check if the remote control and flight control are turned on - Check the resistance of the black and white cables. If short circuit, contact after-sales.
Continuous (1 long flash + 1 short flash)	Throttle is not zeroed.	If occurs when motors rotating. Please check if any short circuit on the battery and cables.
Continuous (1 long flash + 2 short flashes)	MOS over-temp (over 110°C)	Re-power on after the motor cover cooled down.
Continuous (1 long flash + 3 short flashes)	Capacitor over-temp (over 110°C)	Re-power on after the motor cover cooled down.
Continuous (1 long flash + 4 short flashes)	Triggering stall protection	- Restart after the throttle zeroed. - Check if any foreign object in the motor, remove it before restarting.

Continuous (2 long flashes)	Hardware protection, open circuit in the high-side bridge.	-Check if the motor cables are intact. -Contact after-sales.
Continuous (2 long flashes + 1 short flash)	Hardware protection, open circuit in the high-side bridge.	-Check if the motors are intact. -Contact after-sales.
Continuous (2 long flashes + 2 short flashes)	Motor phase loss and wire breakage.	
Continuous (2 long flashes + 3 short flashes)	ESC fault, A phase op amp abnormality	If the fault persists after multiple power-ups, please contact after-sales.
Continuous (2 long flashes + 4 short flashes)	ESC fault, B phase op amp abnormality	
Continuous (3 long flashes)	ESC fault, C phase op amp abnormality	

4.5.3 Battery indicator light

RGB light Signals					
Status	R	G	B	Color	
Normal		1		Green	
Protection	1	1		Yellow	
Alert	1	1	1	White	
Permanent Failure 1	1			Red	
Self-discharge state/balanced state		1	1	Blue	

Short press the switch button, the indicator light will display the battery status.

RGB green LED: The green LED is always on, and the white LED flashes to show SOC. In this state, the battery is normal (charging, discharging, after the communication connection button is pressed)

RGB yellow LED: The battery is in a protected state and can be reused after meeting protection release conditions.

RGB white LED: The battery is in alarm state.

RGB red LED: The battery SOH service life has expired.

RGB blue LED: The blue LED is always on, the battery is in self-discharge state or balanced state.

Power-off state: short press + long press 2S to power on.

Power-on state: Short press + long press to power off.

4.6 Headlight Instruction

Z80 agricultural drone is equipped with an 80W headlight with an illumination range of 25 meters, safeguarding night operations.

In Flight Assistant APP- **setting-Flight-Led Switch**, turn on or turn off, or set **Len Brightness**. The default brightness on the ground is 20% (to avoid high brightness and high temperature damage to the headlight,

the brightness cannot be adjusted at will on the ground).

After takeoff, the headlight will automatically adjust to the set value. The brightness can be adjusted as needed during flight.



* Do not use the headlight to illuminate the eyes to avoid strong light causing damage.

4.7 Battery Instructions

Install the battery, first short press and then long press the power button to turn it on. After the flight, when the propellers stop, short press and then long press to turn off the battery, and then disconnect it from the drone.

Before each flight, ensure the battery power is above 95%. If it alarms for low battery, land and stop flying as soon as possible, replace the battery before next operation.



Battery Precaution:

- *Do not charge the battery if it is damaged, swollen, or leaking.
- *Stop using when the cell temperature is higher than 60°C.
- *Please charge the battery within 0 - 75°C ambient temp.
- *Do not store the battery in direct sunlight, rain, or a humid environment.
- *If unused long, charge and discharge the battery every 2 months for activation.
- *If the battery light is red, the battery cannot be used any more.



Battery spontaneous combustion precautions:

- * Immediately keep the battery away from flammable materials, place it in an open area or throw it into water;
 - * Battery combustion may produce harmful gases or release toxic chemicals.
 - * Please ensure personnel safety and handle the accident properly
-

Battery storage:

- 1) The battery storage temperature must be within -20~35°C;
- 2) For long-term battery storage (more than 3 months), keep in an environment at 23 ± 5°C and 75 ≤ %RH.
- 3) The storage voltage is 67.5V~70.2V(cell 3.75~3.9V), and full-charge storage is prohibited.

4.8 Charger Instructions

4.8.1 Charger Interface

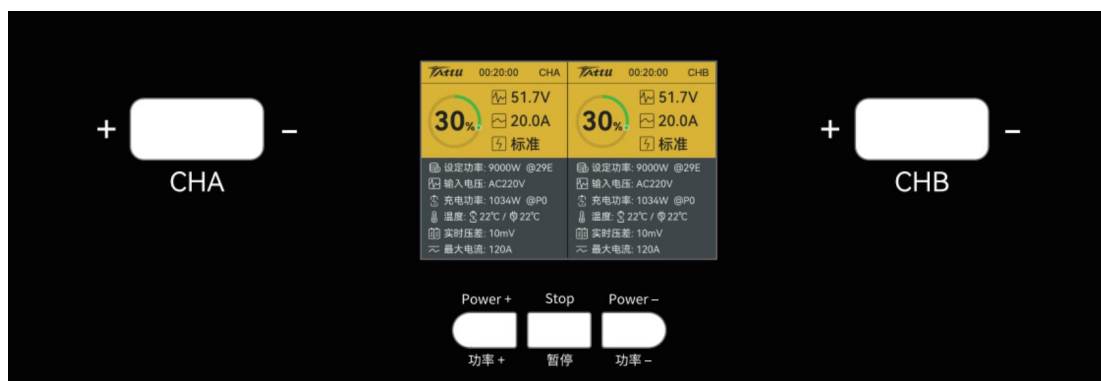

Button	Mode	Function
Power+	Short press	Increase power
	Long press	Switch charging mode (standard/fast charge)
Power-	Short press	Reduce power
Stop	Short press	For checking cell voltage
	Long press	For setting

4.8.2 Charger Usage

Connect one end of the power cord to the charger's AC input and the other to the power socket. Short press the switch. The charger screen shows the boot interface and switches to the main page in about 3 seconds.

Connect the Smart battery

The battery is connected to the charger. If communication is successful, the icon on the main interface turns yellow. There is no need to set the charging current — the system automatically matches the optimal charging parameters. When the countdown ends, smart charging starts automatically. If you need to pause charging, press and hold the pause button to stop. Press and hold it again to resume charging.

Optional Standard/Fast-charging modes.

Standard mode: Charging stops when the SOC reaches 100%.

Fast mode: Charging stops when the SOC reaches 96%.



*High current and temperature during charging. For safety, do not touch charger output port and cord directly. Do not unplug battery directly, long press Pause button and then unplug it.

*The charger can be connected to two batteries at the same time. When one battery is fully charged, it will automatically charge the other battery. (Cannot be charged at the same time)

5 Maintenance

5.1 Drone Maintenance

After the operations, the drone needs to be maintained and cleaned.

- Step 1: Pour soapy water into the tank to neutralize the residues; Then turn on the drone and remote control. Set Spray(L/min) and Nozzle Speed(100%) to the maximum in Work Parameters, turn on the pump and nozzle, and start spraying to clean the residues in the water pump, flow meter, nozzle and water pipe;
- Step 2: Remove the filters at the gate and bottom of tank , and clean the stubborn impurities;
- Step 3: Pour clean water into tank again and spray to empty it for a thorough cleaning of the tank and pipes;
- Step 4: Turn off the drone and wash the drone body. After rinsing, wipe it clean with a wet cloth.

It is necessary to wipe the frame, motor, propellers, centrifugal nozzles, camera, front and rear radars, altitude radar, water pump, flow meter, and level gauge to prevent corrosion and failures. And check if all the screws are tightened. Replace any deformed,damaged,corroded part and cable if found.

Finally, make sure the drone is dry and clean, and the maintenance is completed.

5.2 Battery Maintenance

If the battery plug is oxidized and blackened, clean and maintain it promptly.

- Step1: prepare the tools : 75% or 95% alcohol, wooden sticks, tweezers, cotton swabs,lint-free cloth;
- Step2: Pour alcohol into a cup. Dip a cotton swab and clean each copper plate on the battery plug until the black stains are removed;
- Step3: Further clean with lint-free cloth. Soak the cloth in alcohol, then use a flat wooden stick to insert the cloth into the gaps between the copper plates. Ensure each copper plate and gap is thoroughly cleaned and dry before using.



*If any burn marks exist on plugs of the drone and the battery, replace damaged plugs promptly.

*If copper sheets beside battery plug holes are slightly deformed, use tweezers to restore. If severely deformed, replace battery plugs.

5.3 Updates

Users can upgrade the firmwares of flight control, remote control, etc. in Flight Assistant APP. The steps are as follows:

- Step 1: Turn on and connect the remote control and the drone;
- Step 2: If a new firmware needs upgrading, a yellow dot will appear at the **Device** in the APP. Open

it and tap **Aircraft** to enter the upgrade page;

- Step 3: Click green **Upgrade** and complete the firmware upgrade according to the page prompts.

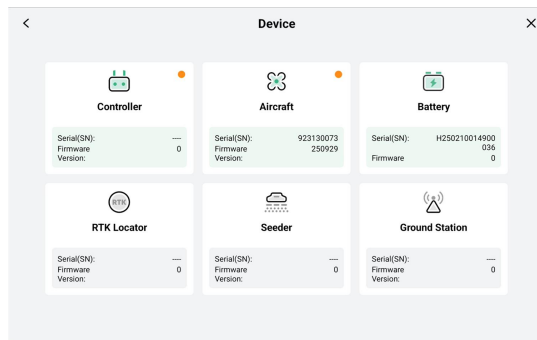

Name	SN	Activation Time	Version	Action
FC	923130073	---	FMU 250929 PMU 250905	Upgrade
F-Radar	---	---	E10V240905	Upgrade
B-Radar	---	---	E20V250106	Upgrade
Terrain Radar	radar_1	---	EB00240410	Upgrade
Pump 1	---	---	---	Upgrade
Pump 2	---	---	---	Upgrade
Centrifugal nozzle 1	---	---	---	Upgrade
Centrifugal nozzle 2	---	---	---	Upgrade

6 Specifications and Appendix

6.1 Specifications

Specifications

Parameters	Z80		
	Spray	Spread	Lift
Weight (without battery)	54.5kg	55.2kg	46.8kg
Weight (with battery)	70.7kg	71.4	63kg
Max Payload	149.9kg		
Wheelbase	2080mm		
Unfolded Size	3283*3283*903mm	3283*3283*1076mm	3283*3283*903mm
Folded Size	1146*1146*885mm	1146*1146*1058mm	1146*1146*885mm
Working Temp.	0-40°C		

 * The weight parameters vary by ±1kg according to the configuration and craft.

* Size parameters vary by ±1cm.

Dimensions

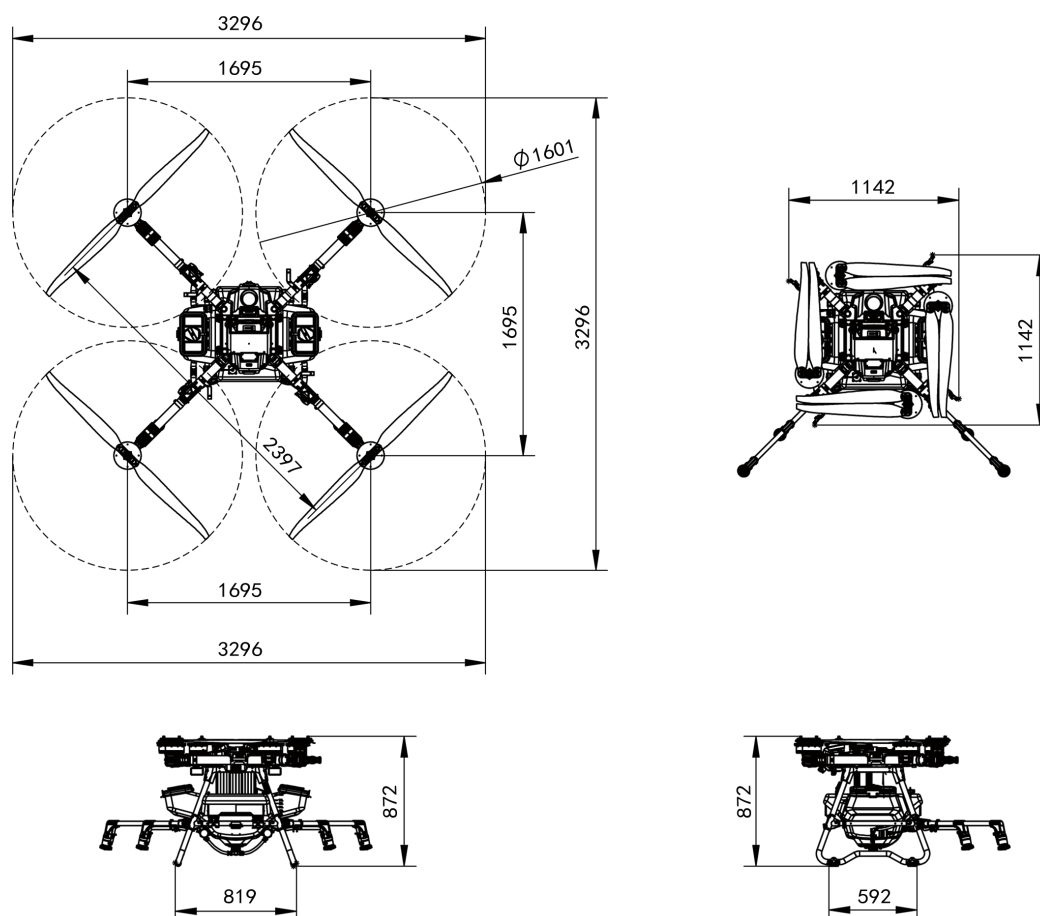

6.2 Disclaimer

Agricultural Drone Disclaimer

Dear User,

Before using this agricultural drone product, please read and fully understand this Disclaimer. Use of this agricultural drone indicates that you have fully accepted and agreed to all the terms of this statement.

I. Operational Qualifications and Training

This drone is intended for use only by personnel who have received professional training and possess the appropriate operational qualifications. Users are solely responsible for obtaining and maintaining all legally required certifications and compliance. Any consequences arising from failure to comply with relevant regulations, including but not limited to legal liabilities, fines, personal injury, or property damage, shall be borne solely by the user. The Company assumes no responsibility.

II. Flight Environment and Restrictions

The user is responsible for operating the drone in a lawful, safe, and suitable flight environment. Do not fly in no-fly or restricted areas (airports, military zones, crowded areas, sensitive sites) or in bad weather (strong wind, heavy rain, lightning, fog). The user is fully responsible for any accidents or legal issues caused by violations. Any accidents, disputes, or legal liabilities resulting from violations of these requirements shall be the sole responsibility of the user.

Users must fully understand and comply with all requirements and restrictions imposed by local aviation authorities and applicable laws and regulations. The company shall not be liable for any adverse consequences arising from the user's lack of knowledge of, or violation of, such rules.

III. Equipment Inspection and Maintenance

Users shall strictly follow the requirements of this User Manual and conduct comprehensive and careful inspections and maintenance of the drone and related equipment before, during, and after each flight to ensure that the equipment remains in good working condition. Any equipment failure, flight accident, or other adverse consequence caused by failure to fulfill these obligations shall be the sole responsibility of the user.

For equipment damage or failure resulting from natural aging, wear and tear, or force majeure, the company will provide repair or replacement services in accordance with applicable warranty terms. However, the company shall not be liable for any indirect losses resulting therefrom, including but not limited to agricultural production losses caused by operational delays or third-party claims arising from equipment failure.

IV. Pesticide and Material Use

When using the agricultural drone for pesticide spraying or material spreading, operators must strictly follow the relevant guidelines and safety procedures, including but not limited to correct mixing concentrations, appropriate operating heights and speeds, and measures to prevent pesticide drift or contamination. The user is solely responsible for any environmental pollution, personal injury, crop damage, or any legal or financial liabilities resulting from improper operation during pesticide or material use. The company assumes no responsibility for any such incidents.

Users are also responsible for ensuring that the pesticides and materials used are compatible with the agricultural drone and bear all risks and liabilities for equipment damage or operation failure caused by incompatibility.

V. Data Security and Privacy

All data generated during the use of the agricultural drone (including but not limited to flight trajectory data, operational data, and image data) shall be stored, used, transmitted, and protected solely at the user's responsibility. Users shall take necessary security measures to prevent data loss, leakage, or unauthorized use. The company assumes no responsibility for any losses or legal disputes arising from data security issues.

The company shall not be liable for any privacy infringement or related issues that may arise during data collection. Users must ensure that their data collection activities comply with applicable laws, regulations, and ethical standards.

VI. Accidents and Losses

Although safety has been fully considered in the design and manufacturing of this agricultural drone, drone flight inherently involves certain risks. Accidents such as crashes, collisions, or loss of control may still occur during use. Users shall purchase and maintain adequate insurance coverage (including but not limited to third-party liability insurance and equipment property insurance) to cover potential risks and losses. Any losses exceeding insurance coverage, or resulting from failure to obtain adequate insurance, shall be borne by the user.

The company is not liable for any damages or losses—direct, indirect, incidental, special, or punitive—arising from the use of the drone, including personal injury, property damage, data loss, or reputational harm, even if the company was aware of the potential for such damages..

VII. After-Sales Service

The company's after-sales service is limited to hardware failures occurring under normal use.. Services include, but are not limited to, repair or replacement of defective components and necessary technical support and consultation during the warranty period.

Applications for after-sales service must follow the company policy. Users shall contact customer service upon discovering a product fault and provide relevant informations as instructed, such as fault descriptions, product serial numbers, and proof of purchase.

For products beyond the warranty period, damage caused by user actions (such as collisions, water ingress, or unauthorized modifications), or failures caused by force majeure, the company reserves the right to refuse free after-sales service or to charge reasonable fees based on actual circumstances.

After-sales response times and repair durations depend on the complexity of the issue and parts availability. While the company will make reasonable efforts to complete repairs timely , no guarantee is made to resolve all issues within a specific timeframe. The company is not liable for any delays or inconveniences resulting from the after-sales service process.

IX. Governing Law and Dispute Resolution

This Disclaimer shall be governed by the laws of the People's Republic of China. Any dispute arising from this Disclaimer or the use of the agricultural drone shall first be resolved through friendly negotiation. If negotiation fails, either party may bring a lawsuit before a competent People's Court with jurisdiction. Please confirm once again that you fully understand and accept all terms of this disclaimer before using this agricultural drone product. If you have any questions regarding any provision of this statement, please consult the company's customer service or a professional legal advisor before use.

Thank you for reading this manual.
For any questions or suggestions,
please contact official after-sales.



ID:eftdrone



ID:eftdrone



ID:@EFFdrone



ID:EFT Electronic Technology
Co., Ltd

Tel: 0551-62579736 Email: infor@effort-tech.com

The manual is subject to update without prior notice. Please stay tuned to official website: www.effort-tech.com.